

# **MURPHYS SANITARY DISTRICT**

## **USE ORDINANCE**

**No. 2**

**09/12/19**

ORDINANCE NO. 2

MURPHYS SEWER DISTRICT SEWER ORDINANCE

ARTICLE I. DEFINITIONS

Sections:

02.01.010	Additional definitions.
02.01.020	Applicability.
02.01.030	Applicant.
02.01.040	As constructed map.
02.01.050	Board.
02.01.060	Building.
02.01.070	Building sewer.
02.01.080	Clerk.
02.01.090	Commercial
02.01.099	New Connection
02.01.100	Connection fee.
02.01.110	Contractor.
02.01.120	Customer.
02.01.130	District.
02.01.140	District Engineer.
02.01.150	District Inspector
02.01.160	Garbage.
02.01.170	General Manager.
02.01.175	Operations Manager.
02.01.180	Lateral sewer.
02.01.190	Main sewer
02.01.200	Multi-family dwelling.
02.01.201	Office Supervisor.
02.01.210	Outside sewer.
02.01.220	Permit.
02.01.230	Person.
02.01.240	Private sewer.
02.01.250	Public sewer.
02.01.260	Sanitary sewer.
02.01.270	Sewage.
02.01.280	Sewage treatment plant.
02.01.290	Sewage works.
02.01.300	Sewer.

- 02.01.310 Sewer service charges.
- 02.01.320 Side sewer.
- 02.01.330 Single-family dwelling.
- 02.01.340 Storm drain.
- 02.01.350 Street.
- 02.01.360 Vacant Lot.

## ARTICLE II. GENERAL PROVISIONS

### Sections:

- 02.02.010 Purpose.
- 02.02.020 Rules and regulations.
- 02.02.030 Short title.
- 02.02.040 Violation unlawful.
- 02.02.050 Relief on application.
- 02.02.055 Destroyed Facilities
- 02.02.060 Relief on own motion.
- 02.02.070 Abandonment of facilities.
- 02.02.080 Agency approvals.
- 02.02.090 Control of work.
- 02.02.100 Right of way.

## ARTICLE III. USE OF PUBLIC SEWERS REQUIRED

- 02.03.010 Disposal of wastes.
- 02.03.020 Treatment of wastes required.
- 02.03.030 Unlawful disposal.
- 02.03.040 Occupancy prohibited.
- 02.03.050 Sewer required.

## ARTICLE IV. BUILDING SEWERS, LATERAL SEWERS AND CONNECTIONS

- 02.04.010 Permit required.
- 02.04.020 Construction requirements.
- 02.04.030 Separate side sewers.
- 02.04.040 Old building sewers.
- 02.04.050 Sewer lifted by artificial means.
- 02.04.060 Connection to public sewer.
- 02.04.070 Protection of excavation.
- 02.04.080 Maintenance of building sewer.
- 02.04.090 Backwater prevention devices maintenance.
- 02.04.100 Testing required.

ARTICLE V. PUBLIC SEWER CONSTRUCTION

- 02.05.010 Permit required.
- 02.05.020 Plans, Profiles, and specifications required.
- 02.05.030 Subdivisions.
- 02.05.040 Easements or rights-of-way.
- 02.05.050 Persons authorized to perform work.
- 02.05.060 Grade stakes.
- 02.05.070 Compliance with regulations.
- 02.05.080 Protection of excavation.
- 02.05.090 Design and construction standards.
- 02.05.100 Completion of sewer required.
- 02.05.110 Improvement security.
- 02.05.120 Financing - General.
- 02.05.130 Special reimbursements agreements.
- 02.05.140 District participation.

ARTICLE VI. USE OF PUBLIC SEWERS

- 02.06.010 Drainage into sewers prohibited.
- 02.06.020 Lot splits and subdivision.
- 02.06.030 Standards for waste entering sewer.
- 02.06.040 Interceptors required.
- 02.06.050 Maintenance of interceptors.
- 02.06.060 Preliminary treatment of wastes.
- 02.06.070 Maintenance of pretreatment facilities.
- 02.06.075 Collection system maintenance responsibility

ARTICLE VII. PERMITS AND FEES

- 02.07.010 Permit required.
- 02.07.020 Application for permit and payment of charges.
- 02.07.030 Compliance with permit.
- 02.07.040 Agreement.
- 02.07.050 Time limit on permits.
- 02.07.060 Fees for annexations.
- 02.07.070 Connection fees.
- 02.07.080 Additional sewer permit and inspection fees.
- 02.07.090 All work to be inspected.
- 02.07.100 Notification.
- 02.07.110 Condemned work.
- 02.07.120 All costs paid by owner.

- 02.07.130 Outside sewers.
- 02.07.140 Encroachment permit.
- 02.07.150 Liability.

#### ARTICLE VIII. SEWER SERVICE RATES

- 02.08.010 Rate schedule.
- 02.08.020 Power to inspect premises.
- 02.08.030 Vacancy.
- 02.08.040 Refunds.
- 02.08.050 Collection of sewer service charges.
- 02.08.060 Due date of sewer service charges.
- 02.08.070 Persons responsible.
- 02.08.080 Delinquency date.
- 02.08.090 Penalties for nonpayment.

#### ARTICLE IX. MANAGEMENT AND ENFORCEMENT

- 02.09.010 Manager - Enforcement responsibility.
- 02.09.020 Delinquency - collection actions.
- 02.09.030 Violations.
- 02.09.040 Public nuisance - Abatement.
- 02.09.050 Infraction.
- 02.09.060 Liability for violation.

#### ARTICLE X. MISCELLANEOUS

- 02.10.010 Protection from damage.
- 02.10.020 Powers and authorities of inspectors.
- 02.10.030 Separability.
- 02.10.040 Inapplicability of inconsistent ordinances.

## ARTICLE I. DEFINITIONS

02.01.010 Additional definitions. For the purpose of this ordinance, additional terms shall have the meaning indicated in Chapter I of the latest edition of Western Plumbing Officials Uniform Plumbing Code, adopted by the Western Plumbing Officials Association, copies of which can be found on file in the District Office.

02.01.011 Administration Manager. or designee shall mean the person or persons appointed by the Board to administer and enforce the policies, rules and regulations of the District.

02.01.015 Accessory Dwelling Unit. (Per Calaveras County Code of Ordinances Chapter 17.66) (Per CA Gov Code §65852.2) An Accessory dwelling unit (ADU) means an attached or detached residential dwelling unit which provides complete independent living facilities for one or more persons. It shall include permanent provisions for living, sleeping, eating, cooking, and sanitation on the same parcel as the single-family dwelling is situated. (See Gov Codes for complete definitions.)

02.01.020 Applicability. Unless the context specifically indicates otherwise, the meaning of terms used in this ordinance shall be as set out in this article.

02.01.030 Applicant. “Applicant” shall mean the person making application for a permit for a sewer installation and shall be the owner of premises to be served by the sewer for which a permit is required or his authorized agent.

02.01.040 As constructed map (Record Drawing). “As constructed map” means a signed plan that reflects and accurately describes what improvements have been constructed. Any difference between the constructed map and the District’s Engineer’s approved plans must have been approved by the District Engineer. All measurements must be taken accurately from a known point and dimensioned on a reproducible paper, and be neat and legible. The District Engineer must approve the “as constructed map” before acceptance by the Board.

02.01.050 Board. “Board” shall mean the Board of directors of the Murphys Sanitary District.

02.01.060 Building. “Building” shall mean any structure used for human habitation or a place of business, recreation or other purpose containing sanitary facilities.

02.01.070 Building sewer. “Building sewer” shall mean that portion of any sewer beginning at the plumbing or drainage outlet of any building or industrial facility and running to the property line or to a private sewage disposal system.

02.01.080 Clerk “Clerk” shall mean the designee of the Board of Directors of the Murphys Sanitary District.

02.01.090 Commercial “Commercial” shall mean any premises used for commercial or business purposes.

02.01.099 New Connection - A connection charge is assigned to a property whenever construction results in the creation of additional dwellings, unit(s) or structures connecting to the sanitary sewer system or building sewer laterals. The intention of the charge is to ensure that increased uses of the system will bear their fair share of the capital cost of the system.

02.01.100 Connection fee. “Connection fee” shall mean a fee which includes all fees and charges that must be paid before a connection permit is issued.

02.01.110 Contractor. “Contractor” shall mean an individual, firm, corporation, partnership or association duly licensed by the State of California to perform the type of work to be done under the permit.

02.01.120 Customer. “Customer” shall mean any firm, person, corporation, association, or governmental agency served by the District for compensation.

02.01.130 District. “District shall mean the Murphys Sanitary District, Calaveras County, California.

02.01.140 District Engineer. “District Engineer” shall mean the engineer appointed by the Board to administer and enforce the rules and regulations of the District and shall be a licensed California Civil Engineer.

02.01.150 District inspector. “District inspector” shall mean the inspector acting for the Board, the District Engineer or inspector appointed by the Board.

02.01.160 Garbage. “Garbage” shall mean solid wastes from the preparation, cooking, dispensing of food, and from the handling, storage and sale of produce.

02.01.170 General Manager. “General Manager” or designee shall mean the person or persons appointed by the Board to administer and enforce the rules and regulations of the District.

02.01.175 Operations Manager. “Operations Manager” or designee shall be the person designated by the Board to manage the sewer operations.

02.01.180 Lateral sewer. “Lateral sewer” shall mean the portion of a sewer

lying within a public street connecting a building sewer to the main sewer.

02.01.190 Main sewer. “Main sewer” shall mean a public sewer designed to accommodate more than one lateral sewer.

02.01.200 Multi-family dwelling. “Multi-family dwelling” shall mean any premises designed, improved or used as a residence for two or more families living independently of each other in two or more structurally joined dwelling units with separate entrances. This term shall include apartment houses and duplexes, but it shall not include hotels, motels, dormitories, or similar structures.

02.01.201 Office Supervisor. A person employed by the District to perform the business affairs of the District office.

02.01.210 Outside sewer. “Outside sewer” shall mean a sanitary sewer beyond the limits of the District and not subject to the control or jurisdiction of the District.

02.01.220 Permit. “Permit” shall mean any written authorization required pursuant to this or any other regulations of the District for the installation of any sewage works in the District. The Permittee shall be the owner or the appointed representative of the owner.

02.01.230 Person. “Person” shall mean any human being, individual, firm, company, partnership, association, private or public or municipal corporations, the United States of America, the State of California, Districts, and all political entities, and governmental agencies.

02.01.240 Private sewer. “Private sewer” shall mean a sewer serving an independent sewage disposal system not connected with a public sewer which accommodates one or more buildings or industries.

02.01.250 Public sewer. “Public sewer” shall mean a sewer lying within a street and which is controlled by or under the jurisdiction of the District.

02.01.260 Sanitary sewer. “Sanitary sewer” shall mean a sewer which only carries sewage.

02.01.270 Sewage. “Sewage” shall mean a combination of water-carried wastes from residences, business building, institutions and industrial establishments, as may enter the District’s sewer system.

02.01.280 Sewage treatment plant. “Sewage treatment plant” shall mean any



arrangement of devices and structures used for treating and disposing of sewage.

02.01.290 Sewage works. “Sewage works” shall mean all facilities for collecting, pumping, treating and disposing of sewage.

02.01.300 Sewer. “Sewer” shall mean a pipe or conduit for carrying sewage.

02.01.310 Sewer service charges. “Sewer service charges” means sewer capacity charges, fees, tolls, rates, rentals or other charges for service and facilities furnished by the District in connection with its sewage system

02.01.320 Side sewer. “Side sewer” shall mean the sewer line beginning at the foundation wall of any building and terminating at the main sewer and shall include the building sewer and lateral sewer together.

02.01.330 Single-family dwelling. “Single-family dwelling” shall mean premises designed, improved or used as a residence for one household only and for no other purposes.

02.01.331 Single-family residence. “Single-family residence” (SFR) shall mean premises designed, improved or used as a residence for one household only and for no other purposes.

02.01.332 Single-family unit. “Single-family unit” (SFU) shall mean premises designed, improved or used as a residence for one household only and for no other purposes.

02.01.340 Storm drain. “Storm drain” shall mean a conduit, which carries storm and surface or ground waters and drainage, but excludes sewage and industrial wastes.

02.01.350 Street. “Street” shall mean any public highway, road, street, avenue, alley way, public place, public easement or right-of-way.

02.01.351 Undeveloped Property. A vacant lot within the District boundaries for which no sewer connection permit or fees have been paid but on which no building exists.

02.01.360 Vacant Lot - “Vacant Lot” for which a connection fee and all other permit fees has been paid but on which no building exists.

## ARTICLE II. GENERAL PROVISIONS

02.02.010 Purpose. This ordinance is intended to provide rules and regulations for the use and construction of sanitary sewer facilities hereafter installed, altered or repaired within the District. This ordinance shall not apply retroactively and, in the event of an alteration or repair hereafter made, it shall apply only to new materials and methods used therein.

02.02.020 Rules and Regulations. The following rules and regulations respecting sewer construction and disposal of sewage and connection to the sewage works in the District are adopted, and all work in respect thereto shall be performed as required in this ordinance and not otherwise.

02.02.030 Short title. This ordinance shall be known as the “Murphys Sanitary District Use Ordinance.”

02.02.040 Violation unlawful. Following the effective date of this ordinance, it is unlawful for any person to connect to, construct, install or provide, maintain and use any other means of sewage disposal from any building in said District except by connection to a public sewer in the manner as provided in this ordinance.

02.02.050 Relief on application. When any person, by reason of special circumstances, is of the opinion that any provision of this ordinance is unjust or inequitable as applied to his/her premises, he/she may make written application to the Board, stating the special circumstances, citing the provision complained of, and requesting suspension or modification of that provision as applied to his/her premises. If such application is approved, the Board may, by order, suspend or modify the provision complained of, as applied to such premises, to be effective as of the date of the application and continuing during the period of the special circumstances. This one-time relief action shall not constitute a precedence or permanent change or waiver to this ordinance.

### 02.02.055 Destroyed Facilities

A single-family dwelling, an apartment building or a commercial facility that has been destroyed by fire, earthquake or other natural disaster or has been destroyed or removed by the current property owner may get relief for monthly sewer rate payments by the owner of the impacted property filing a written request with the Board. Upon approval of the request by the Board, the yearly rate will be \$100/year. This reduced rate will be adjusted should any new monthly sewer rate be adopted by the Board. The reduction will become effective the first month following the month in which the reduction was approved by the Board. The reduced rate will remain in effect for up to five (5) years or the construction of a new facility. The current monthly sewer rate for the new facility will

begin when the new facility sewer becomes usable or when an occupancy permit is issued by the County, whichever occurs first. *Note, prior to the construction of a new facility, the owner must file a new application for a connection permit from the District.* If a new facility has not been completed within five (5) years, the property owner may seek a five (5) year relief extension if requested from the Board prior to the expiration of the original approved five (5) year relief period. At the completion of the original approved five (5) year relief period, or at the completion of the approved five (5) year extension period, the property owner must resume paying the current monthly sewer rate. If the owner elects not to resume paying the current monthly sewer rate, the District will no longer consider the connection as valid and will require any future construction on said property to be subject to all costs and fees including a new connection fee for any future use of the sewer system.

02.02.060 Relief on own motion. The Board may, on its own motion, find that by reason of special circumstances any provision of these regulations should be suspended or modified as applied to a particular premise and may, by resolution, order such suspension or modification for such premises during the period of such special circumstances, or any part thereof.

02.02.070 Abandonment of facilities. At such time as a public sewer becomes available to a property served by a private sewage disposal system, a direct connection shall be made to the public sewer in compliance with this ordinance and rules and regulations of the District, and any septic tanks, cesspools and similar private sewage disposal facilities shall be abandoned and filled with suitable material as determined by the Calaveras County Health Department.

02.02.080 Agency approvals. It shall be the responsibility of the applicant to obtain all approvals required from applicable public agencies regarding the proposed construction. Such agencies may include but are not limited to Calaveras County, Department of Fish and Game, and the Central Valley Regional Water Quality Control Board.

02.02.090 Control of work.

A. A minimum of 48 hours-notice shall be given to the District prior to the commencement of work. A minimum of 48 hours shall be given to the District prior to any phase of work requiring disruption of service. Connection to existing facilities shall be approved by the Operations Manager or designee and the District Engineer prior to the commencement of that phase of work.

B. It shall be the Contractor's responsibility to ascertain possible conflicts with underground utilities, locate said utilities in advance of work, and notify all applicable agencies and acquire any and all required permission and/or permits.

C. Underground facilities location requests, other than emergency, should be referred to 'Underground Service Alert Program' (USA). Surface marking on located underground facilities will be in accordance with the USA recommended color codes:

Blue-Water  
Red-Electric  
Yellow-Gas  
Green-Sewer  
Orange-Telephone

02.02.100 Right of way. All facilities to be operated or maintained by the District shall be located in public rights of way. When facilities cannot be so located, they shall be located in public utility easements dedicated to the District. The location and width of easements shall be subject to approval of the District Engineer.

### ARTICLE III. USE OF PUBLIC SEWERS REQUIRED

02.03.010 Disposal of wastes. It is unlawful for any person to place, deposit or permit to be deposited in an unsanitary manner upon public or private property within the District any human or animal excrement, garbage, refuse or other objectionable waste.

02.03.020 Treatment of wastes required. It is unlawful to discharge to any stream or watercourse any sewage, industrial wastes, or other polluted waters, except where suitable treatment has been provided in accordance with the provisions of this ordinance.

02.03.030 Unlawful disposal. Except as herein provided in the ordinance, it is unlawful to construct or maintain in the District any privy, privy vault, septic tank, cesspool, seepage pit or other facility intended or used for disposal of sewage.

02.03.040 Occupancy prohibited. No building, industrial facility or other structure shall be occupied until the owner of the premises has complied with all rules and regulations of the District.

02.03.050 Separate sewer connection required for each building.

A. The owner of any building situated within the District is required at his/her expense to connect said building directly with the proper public sewer in accordance with provisions of this ordinance, within thirty (30) days after date of official notice to do so and prior to any occupancy of said building.

B. A separate and independent private sewer shall be provided for every building within the District prior to any occupancy of said building. Other buildings unattached to single family dwellings within the same parcel boundaries shall be exempt unless they require a sewer connection for disposal of wastewater generated therein. All

connections to public sewers shall include a clean out of a specific type that includes a lock out capability and placed at the property line or other appropriate location as approved by the District Engineer\Operations Manager.

#### ARTICLE IV. BUILDING SEWERS, LATERAL SEWERS AND CONNECTIONS

02.04.010 Permit required. In accordance with this ordinance, no person shall construct a building sewer, lateral sewer or make a connection with any public sewer without first obtaining a written permit from the District and paying all fees and connection charges as required herein.

02.04.020 Construction requirements. Construction of building sewers and lateral sewers shall be in accordance with the requirements of the current Uniform Plumbing Code.

02.04.030 Separate side sewers.

A. Each building shall be connected to a separate side sewer which includes both the building sewer and the lateral sewer together.

B. Notwithstanding the provisions of this section, single-family residential units with common walls, condominium, stock cooperative, community apartments or other similar improvements which entitle owners of interests therein to occupy independent ownership interests and to make joint use of utility and other services, which may be provided by facilities owned in common, may apply for a relief of application, and upon issuance of a permit authorizing such common use by the District, be permitted to maintain a common building sewer or sewers.

02.04.040 Old building sewers. Old building sewers may be used in connection with new buildings only when they are found, upon examination and test, witnessed by the District inspector, to meet all requirements.

02.04.050 Sewer lifted by artificial means. In all buildings in which any building sewer is too low to permit gravity flow to the public sewer, sanitary sewage carried by such building sewer shall be lifted by artificial means (pump station) approved by the District Engineer, and discharged to the public sewer at the expense of the owner. The owner shall be responsible for all maintenance and repairs of the pump station.

02.04.060 Connection to public sewer. The connection of the building sewer into the public sewer shall be made at the lateral or "Y" branch, if such lateral or "Y" branch is available at a suitable location. Where no properly located "Y" branch is available; the District will install one at the owner's expense. The invert of the building or lateral sewer at the point of connection shall be at a higher elevation than the invert of the public sewer. The connection to the public sewer shall be made in the presence of the

District inspector and under his/her supervision and direction. Any damage to the public sewer shall be repaired at the expense of the applicant and constructed to the satisfaction of the District inspector.

02.04.070 Protection of excavation. All excavations for a sewer installation shall be adequately guarded with barricades or lights so as to protect the public from hazard. Streets, sidewalks, parkways and other property disturbed in the course of the work shall be restored in a manner satisfactory to the District or any other person having jurisdiction thereof.

02.04.80 Maintenance of side sewer. Responsibility for maintenance of side sewers (including replacement when necessary) is as follows:

A. Building sewers shall be maintained by the owner of the property served thereby. (including replacement when necessary) Where a building sewer provides service to more than one single-family residential unit in a development with common walls, condominium, stock cooperative, community apartments or other similar improvements, the obligation to maintain the building sewer shall be in the homeowners' association or other entity responsible for the maintenance of the property and facilities owned in common.

B. The maintenance of lateral sewers from the building to the district main shall be the responsibility of the property owner(s).

02.04.090 Backwater prevention devices maintenance. Where a side sewer serves plumbing fixtures that are located less than two feet above the rim elevation of the upstream manhole or rod hole in the reach of main sewer into which the side connects, it shall be protected from backflow of sewage by installing a backwater prevention device of a type and in the manner prescribed by the District. Any such back flow device shall be installed by the applicant for sewer service at the sole cost and expense of the applicant. The maintenance of the back-flow device shall be the sole obligation of the permittee or his/her successor in interest. The District shall be under no obligation to ascertain that the backflow device continues in operating condition.

02.04.100 Testing required. All said side or lateral sewers shall be tested and approved by the District inspector.

## ARTICLE V. PUBLIC SEWER CONSTRUCTION

02.05.010 Permit required. No person shall construct or extend any public sewer without first obtaining a written permit from the District and paying all fees and charges and furnishing bonds as required in this ordinance. The provisions of this section requiring permits shall not be construed to apply to contractors constructing sewers and appurtenances under contracts awarded and entered into by the District.

02.05.020 Plans, profiles, and specifications required. The application for a permit for public sewer construction shall be accompanied by two complete sets of plans, profiles, and specifications complying with all applicable ordinances, rules and regulations of the District prepared and stamped by a registered civil engineer, showing all details of the proposed work based on an accurate survey of the ground. The application, together with the plans, profiles and specifications shall be examined by the District Engineer who shall within fifteen (15) business days approve them as filed or require them to be modified as District Engineer deems necessary for proper installation.

02.05.030 Subdivisions. The final subdivision map for any subdivision in the District shall provide for the dedication for public use of all streets, easements or right-of-way in which public sewers are to be constructed.

02.05.040 Easements or right-of-way. In the event that an easement is required for the extension of the public sewer or the making of connections, the applicant shall procure and have accepted by the Board a proper easement or grant of right-of-way sufficient in law to allow the laying and maintenance of such extension or connection.

02.05.050 Persons authorized to perform work. Only properly licensed contractors shall be authorized to perform the work of public sewer construction within the District. All terms and conditions of the permit issued by the District to the applicant shall be binding on the contractor.

02.05.060 Grade stakes. Grade and line stakes shall be set by a registered land surveyor prior to the start of work on any public sewer construction. The contractor shall be responsible for accurately transferring grades to grade bars and sewer invert.

02.05.070 Compliance with regulation. Any person constructing a sewer within a street shall comply with all District, state and County laws, ordinances, rules and regulations pertaining to the cutting of pavement, opening, barricading, lighting and protection of trenches, backfilling, re-paving thereof and shall obtain all permits and pay all required fees prior to the issuance of a permit by the District.

02.05.080 Protection of excavation. The applicant shall maintain such barriers, lights and signs as are necessary to give warning to the public at all times that a

sewer is under construction and of each dangerous condition to be encountered as a result thereof. He/she shall also likewise protect the public in the use of the sidewalk against any such conditions in connection with the construction of sewer. Streets, sidewalks, parkways and other property disturbed in the course of the work shall be reinstalled in a manner satisfactory to the District or any other person having jurisdiction there over.

02.05.090 Design and construction standards.

A. Minimum standards for the design and construction of public sewers within the District shall be in accordance with the current “General Requirements for Sanitary Sewer Installations” as adopted by the Board. Said Standards are incorporated herein as Appendix I and may be reviewed and obtained separately at the District office. The Board may permit modifications or may require higher standards than set forth in said specifications where unusual conditions are encountered.

B. Record drawings (as constructed map) showing the actual location of all mains, structures, “Y”s, laterals, clean-outs, and other construction shall be filed with the District before final acceptance of the work.

02.05.100 Completion of sewer required. Before any acceptance of any sewer line by the District and prior to the admission of any sewage into the system, the sewer line shall be tested and shall be in full compliance with the General Requirements for Sanitary Sewer Installations and to the satisfaction of the District. If the work of constructing public sewage facilities is not completed within the time specified in the permit, the District may extend said time limit or may complete the work and take appropriate steps to enforce the provisions of the improvement security furnished by the permittee pursuant to Article V, section 02.05.110.

02.05.110 Improvement security. Prior to issuance of a permit for public sewer construction, the applicant shall furnish to the District a faithful performance bond, cash, or other improvement security acceptable to the Board, in the amount of 115% of the total estimated cost of the work as determined by the District Engineer. Such faithful performance bond, cash deposit, or other improvement security shall be conditioned upon the performance of the terms and conditions of the permit and, unless more stringent requirements are otherwise specified by the Board, shall guarantee the correction of faulty workmanship and replacement of defective materials for a period of one year from and after the date of acceptance of the work by the Board. The applicant shall also furnish to the District a labor and material bond, or other security acceptable to the District in the amount of the total estimated cost of the work.

02.05.120 Financing–General. Except as provided in this ordinance, the extension of the public sewage facilities to serve any parcel or tract of land shall be done by and at the expense of the owner, although the District reserves the right to perform the work and bill the owner for the cost thereof, to perform the work itself, or to perform the



work pursuant to special assessment proceedings. The cost to the District must be reimbursed in full prior to the admission of any sewage into the District's system. The size of all sewer mains and other sewage facilities shall be as required by the District.

02.05.130 Special reimbursement agreements. Where special conditions exist in the opinion of the District, the Board may either in addition to or in lieu of any of the provisions of this ordinance, authorize a special reimbursement contract between the District and the person or persons constructing public sewage facilities. Said special reimbursement agreement shall be made and entered into prior to the issuance of a permit for the work by the District.

02.05.140 District participation. The District may, at its discretion, pay that portion of the costs of extending its sewage system or constructing sewage pumping or treatment facilities equal to the difference in cost between the size of facility required by installer's development and the size of facility that the District requires.

## ARTICLE VI. USE OF PUBLIC SEWERS

02.06.010 Drainage into sewers prohibited. No leaders from roofs and no surface drains for rainwater shall be connected to any sanitary sewer. No surface or subsurface drainage, rainwater, storm water, seepage, cooling water or unpolluted industrial process waters shall be permitted to enter any sanitary sewer by any device or method whatsoever.

02.06.020 Lot splits and subdivisions.

A. Any land divisions or subdivisions in the District shall require a written statement from the District counsel, or from any attorney acceptable to him/her, that all existing bonds and apportionment of assessments are spread equitably and that all legal requirements regarding any bonds and assessments are in order. The sub-divider shall pay the actual costs incurred by said counsel or other attorney in preparing said statement.

B. Prior to the approval of any final subdivision or parcel map, the District Engineer shall determine whether any new or increased potential use of the existing sewer facilities will occur. If he determines that the existing sewer facilities are inadequate in size and/or design to accommodate additional sewage from said subdivision or parcel map, the applicant shall be required to bear the costs for the construction of the required improved service or services. Reimbursement agreement as set forth in Article V., Section 02.05.130, may be considered by the District.

02.06.030 Standards for waste entering sewer.

A. Prohibited Sewage—Storm or Wash water. Storm water or

pavement wash water shall not be introduced into the sanitary sewer system. Connection of roof drains or surface water drains is prohibited.

B. Prohibited Sewage–Harmful or Dangerous Substances

Designated. No person shall discharge or cause to be discharged the following substances, materials, waters, or wastes if it appears likely in the opinion of the District that such wastes can harm either the sewers, sewage treatment process or equipment; have an adverse effect on the treatment process or equipment; have an adverse effect on the treatment plant; or can otherwise endanger life, limb, public property, or constitutes a nuisance. In forming an opinion as to the acceptability of these wastes, the District will give consideration to such factors as the quantities of subject wastes in relation to flows and velocities in the sewers, materials of construction of the sewers, nature of the sewage treatment process, capacity of the sewage treatment plant, degree of treatability of wastes in the sewage treatment plant, and other pertinent factors. The substances prohibited are:

1. Toxic substances. It is unlawful to discharge any waters or wastes containing toxic or poisonous solids, liquids, or gases in sufficient quantity, either singly or by interaction with other wastes, to injure or interfere with any sewage treatment process which constitutes a hazard to humans or animals, creates a public nuisance, or creates any hazard in the receiving waters of the sewage treatment plant;
2. Any liquid or vapor having a temperature higher than one hundred fifty (150) degrees Fahrenheit;
3. Any water or waste containing fats, wax, grease or oils, whether emulsified or not, in excess of one hundred (100) mg/l or containing substances which may solidify or become viscous at temperatures between thirty-two (32) and one hundred fifty (150) degrees Fahrenheit;
4. Any garbage that has not been properly shredded to such a degree that all particles will be carried freely under flow conditions normally prevailing in public sewers, with no particle greater than one-half inch in any dimension;
5. Any waters containing synthetic detergents in sufficient quantity to injure or interfere with any sewage treatment process or create problems in the receiving waters of the sewage treatment plant;
6. Any waters or wastes containing suspended solids of such character and quantity that unusual attention or expense is required to handle such materials at the sewage treatment plant;
7. Any noxious or malodorous gas or substance capable of creating a public nuisance;
8. Any waters or wastes containing strong acid, iron-pickling wastes, or concentrated plating solutions, whether neutralized or not;
9. Any waters or wastes containing iron, chromium, copper, and zinc and similar objectionable or toxic substances; or wastes exerting an excessive chlorine requirement, to such degree that any such material received in the composite sewage at the sewage treatment works exceeds limits prescribed in the current Waste

Discharge Permit as issued by the Central Valley Regional Water Quality Control Board;

10. Any waters or wastes containing phenols or other taste or odor producing substances in such concentrations exceeding limits which may be established by the Board as necessary, after treatment of the composite sewage, to meet the requirements of the state, federal, or other public agencies of jurisdiction for such discharge to the receiving waters;

11. Any waters or wastes having ph lower than 5.5 or in excess of 9.0;

12. Materials which exert or cause:

a. Unusual concentrations of inert suspended solids (such as, but not limited to, fuller's earth, lime slurries and lime residues) or of dissolved solids (such as, but not limited to, sodium chloride and sodium sulfate),

b. Excessive discoloration (such as, but not limited to, dye wastes and vegetable tanning solutions),

c. Unusual BOD, biochemical oxygen demand, or chlorine requirements in such quantities as to constitute a significant load on the sewage treatment works;

13. Waters or wastes containing substances which are not amenable to treatment or reduction by the sewage treatment processes employed, or are amenable to treatment only to such degree that the sewage treatment plant effluent cannot meet the requirements of other agencies having jurisdiction over discharge to the receiving waters;

14. Water from swimming or wading pools;

15. Any septage sludge;

16. Any chemical or substance that has been determined by the Environmental Protection Agency, the State of California or Calaveras County to pose a health hazard or risk.

C. If any waters or wastes are discharged, or are proposed to be discharged to the public sewer which contain the substances or possess the characteristics enumerated in Section 02.06.030 B and which, in the judgment of the Board, may have a deleterious effect upon the sewage works, create a hazard to life or constitute a public nuisance, the General Manager may:

a. Reject the waste;

b. Require pretreatment to an acceptable condition for discharge to the public sewers.

D. If the Operations Manager or designee permits the pretreatment or the equalization of waste flows, the design and installation of the plants and equipment shall be subject to the review and approval of the Operations Manager or designee, and subject to the requirements of all applicable state, county and District codes, ordinances and laws.

E. Control Manhole when required: When required by the Operations Manager or designee, the owner of any property serviced by a building sewer carrying industrial wastes shall install a suitable control manhole together with such necessary meters and other appurtenances in the building sewer to facilitate observation, sampling and measurement of the wastes. Such manhole, when required, shall be accessible and safely located, and shall be constructed in accordance with plans approved by the District Engineer. The manhole shall be installed by the owner at owners' expense, and shall be maintained by him/her so as to be safe and accessible at all times.

F. Measurement, Tests, and Analyses-Standards: All measurements, tests, and analyses of the characteristics of water and wastes to which reference is made in this ordinance shall be determined in accordance with the latest edition of "Standard Methods for the Examination of Water and Waste-Water," published by the American Public Health Association, and shall be determined at the control manhole provided, or upon suitable samples taken at said control manhole. In the event that no special manhole has been required, the control manhole shall be considered to be the nearest downstream manhole in the public sewer to the point at which the building sewer is connected. Sampling shall be carried out by customarily accepted methods to reflect the effect of constituents upon the sewage works and to determine the existence of hazards to life, limb and property. The particular analyses involved will determine whether a twenty-four (24) hour composite of all outfalls of a premise is appropriate or whether a grab sample or samples should be taken normally. BOD and suspended solids analyses shall be obtained from twenty-four (24) hour composites of all outfalls and pH's shall be determined from periodic grab samples.

**02.06.040 Interceptors required.**

A. Grease, oil and sand interceptors shall be provided when in the opinion of the District, they are necessary for the proper handling of liquid wastes containing fats, oils or grease in excessive amounts, or by flammable wastes, sand, and other harmful ingredients; except that such interceptors shall not be required for buildings used for residential purposes. All interceptors shall be of a type and capacity as approved by the District, and shall be located as to be readily and easily accessible for cleaning and inspection. Grease traps shall be required at all public premises where food is handled or prepared, such as restaurants, cafeterias, boardinghouses, hotels, motels, and markets. Interceptor/Grease Traps shall be maintained to ensure the required capacity and functioning. In the event Interceptor/Grease Trap fails to function as designed or warranted, they shall be immediately repaired or replaced at the sole cost of the responsible party, building owner or business owner.

B. Grease and oil interceptors shall be constructed of impervious materials capable of withstanding abrupt and extreme changes in temperature. They shall be of substantial construction, watertight, and equipped with easily removable covers which when bolted in place shall be gas tight and watertight.

C. Interceptors are to be so located and constructed so as to permit intervening inspection by the District.

D. Interceptors/grease traps will be inspected quarterly. Fees will be collected for this service per District Resolution.

E. Quarterly inspection fees shall cover costs of inspection and one follow up visit per quarter. Each additional follow up visit per quarter shall be charged a sum equivalent to the quarterly inspection fee.

F. Records of Interceptor/grease trap maintenance shall be kept by the responsible party, building owner or business owner, for 3 years and provided to MSD inspector upon request.

G. District shall use the applicable edition of the California Plumbing Code to determine the sizing and capacity for the interceptor/grease trap.

**02.06.050 Maintenance of interceptors.**

A. All fats, oil and sand interceptors shall be maintained by the owner, at his expense, in continuously efficient operation at all times.

B. If the interceptor/grease trap is not maintained, District may have it cleaned at the expense of the responsible party, building owner or business owner.

C. If it is determined that an Interceptor/Grease trap is undersized for the volume of liquid wastes containing fats, oils or grease, District will require that it be replaced with an approved size at the sole cost of the responsible party, building owner or business owner.

**02.06.060 Preliminary treatment of wastes.**

A. The admission into the public sewers of any waters or wastes, having any of the characteristics listed below, shall be subject to the review and approval of the District Engineer.

1. A five (5) day biochemical oxygen demand (BOD) greater than two hundred fifty (250) milligrams per liter (mg/l); or
2. Containing more than two hundred fifty (250) mg/l suspended solids; or
3. Containing any quantity of substance having the characteristics described in Article VI., section 02.06.030; or
4. Having an average daily flow greater than two (2) percent of the average daily sewage flow of the District area.

B. Where necessary in the opinion of the District Engineer, the owner shall provide, at his expense, such preliminary treatment as may be necessary to:

1. Reduce the biochemical oxygen demand (BOD) to two hundred fifty

- (250) mg/1 and the suspended solids to two hundred fifty (250) mg/1;
2. Reduce objectionable characteristics or constituents to within the maximum limits provided for in Article VI., section 02.06.030; or
  3. Control the quantities and rates of discharge of such waters or wastes.

C. Plans, specifications, and other pertinent information relating to proposed preliminary treatment facilities shall be submitted for the approval of the District Engineer and the Regional Water Quality Control Board of the State of California and no construction of such facilities shall be commenced until said approvals are obtained in writing.

02.06.070 Maintenance of pretreatment facilities.

Where preliminary treatment facilities are provided for any waters or wastes, they shall be maintained continuously in satisfactory and effective operation by the owner, at his/her expense.

02.06.075 Collection system maintenance

Should a customer have any sewer problem with any part of the collection system including any portion of the building sewer, side sewer or lateral, the customer must immediately notify Murphys Sanitary District of the problem and wait for the Sanitary District to inspect and advise the customer prior to the customer beginning any repairs. The Sanitary District will not be responsible for any work the customer has performed without District acceptance of responsibility prior to the work being performed. The customer is responsible for any and all maintenance and incurred costs required to repair or replace any portion of a building sewer, side sewer or lateral. Should Sanitary District Staff be unable to determine responsibility for the sewer problem, the Board of Directors will determine how much if any responsibility along with incurred costs will be borne by the District. Should staff determine the problem is the customer's responsibility the customer has the right to petition the board for relief through a written request.

ARTICLE VII. PERMITS AND FEES

02.07.010 Permit Required

No unauthorized person shall uncover, make any connections with or opening into, use, alter, or disturb any public sewer or appurtenance or perform any work on any sewer system without first obtaining a written permit from the District. Once obtained, said permit shall run with the land benefited by the permit and shall be binding on all assignees, heirs, devisees, and other successors in interest to the owner of said land. Transferring of any issued permit to a different parcel will be considered on a case by case basis as requested by the permit holder and prior to expiration of the permit. Transfers of permits purchased for sub-divisions when a will serve has been issued to the County will not be transferable.

02.07.020 Application for Permit.

A. An applicant shall apply for a permit and shall make sure application is on forms provided by the District for this purpose. The application form shall include as a minimum the following information:

1. Name and mailing address of the Owner of the premises.
2. Assessor's parcel number of the project.
3. Service Address.
4. Name and mailing address of the parcel Owner to be billed for user charges.
5. Type of service required.
6. Date of Application.
7. Signature of Applicant.

An application fee shall be paid to the District prior to District review.

B. In the event the applicant for a permit is required to provide plans, specifications or drawings and such other information as a condition to the issuance of the permit, the applicant shall pay all engineering, legal, and other expenses and charges required for the review of required plans and specifications. Proof of easements across private property needed for project will be required.

C. If the District determines, with the advice and concurrence of the District Engineer, that the plans, specifications, drawings and other information furnished by the applicant are satisfactory and are in compliance with the ordinance, rules and regulations of the District, the District shall issue a will serve letter. Included with the will serve letter, the District will identify needed on-site and off-site improvements to handle the proposed development. The applicant will be responsible for paying for the on-site improvements and the rest of the improvements or the proportional costs of off-site improvements in addition to the District's current connection fee, before issuance of a permit.

D. The applicant will be notified if the application is approved or disapproved within fifteen (15) business days of acceptance of application. The Permit shall be good for one (1) calendar year from the date of issuance.

02.07.030 Compliance with permit. After approval of the application, evidenced by the issuance of a permit, no change shall be made in the location of the sewer, the grade, materials, or other details from those described in the permit or as shown on the plans and specifications for which the permit was issued except with written permission from the District, the District Engineer, the District Inspector, or other authorized District representative.

02.07.050 Time limit on permits.

If work under a permit is not commenced and completed within one (1) year from the date of issuance, the permit becomes null and void and no further work shall be done until a new permit has been secured. After said work has been completed and the District has approved and accepted the work, the permit shall be in full force and effect. An extension of one year may be granted if requested from the District Board prior to the expiration of the original permit. Further, no more than one extension will be granted. All permits purchased prior to 01/01/2013 will not have an expiration date. If a permit holder would like to sell back to the District their unexpired permit, the Board will consider each request on a case by case basis. There will be no buy back of permits issued for a sub-division.

02.07.060 Fees and annexations. If the owner of lands outside of the existing District Boundaries wishes to annex into the District, the owner shall deposit with the District a sum to be fixed by the Board, prior to the commencement of proceedings by the Board on proposed annexation. The amount to be fixed by the Board shall be the sum estimated to equal the engineering, legal and publication costs and all other charges which may be incurred by the District in preparing and examining maps, legal descriptions, and other documents in relation thereto, and other expenses regularly incurred in connection therewith. A fee of \$1000 per acre shall be deposited with the District prior to commencement of the annexation process. Should the amount of the deposit exceed the costs incurred by the District, the excess shall be refunded to the owner or owners following the conclusion of the final hearing on the proposed annexation. When the District estimates that the cost of annexation will exceed the process costs, the Owner shall deposit additional monies, based on estimates by the District prior to the final hearing on the proposed annexation or at a time when the expenditures exceed 80% of the deposit. The District is not obligated to annex any or all parcels who make application for annexation.

02.07.070 Connection fees.

A. The owner of each property connecting to the sewer shall pay to the District a sum, which shall include a connection fee which shall be set from time to time by resolution, and all other fees and charges required to be paid pursuant to this ordinance and other rules and regulations of the District, prior to the issuance of a connection permit. If any permit is not used and lapses as provided in Article VII, section 02.07.050, no part of the permit fee shall be refunded.

B. The District may require anyone who applies for a connection to file a statement for the guidance of the District in ascertaining the sewer service rate charge payable under these regulations. If no statement is filed the District will determine the classification and set the fee accordingly. All connection permits must be obtained at least five days prior to the connection to the District's system.



C. All costs and expenses involved with the installation and connection of any private sewer shall be borne by the owner. The owner shall indemnify the District for any loss or damage that may directly or indirectly be occasioned by the installation of a private sewer.

D. In the case of a sewer service for subdivisions, the following shall apply:

1. When a sewer main is available, the developer will extend the sewer service to the nearest edge of the property at the expense of the developer.
2. The District may undertake main line extensions of the sewer at the developer's expense.
3. The cost of the main line extension will be reimbursed to the developer on a pro rata basis as other services connect to the main line within a period not to exceed ten years. However, it is understood that the District will in no event pay to any developer or other person an amount greater than the actual cost of the installation. By the end of the ten-year period from the date of installation completion, if the developer has not been repaid in full, the obligation of the District to reimburse the developer shall terminate.
4. The sewer main shall be installed to District specifications and shall become the property of the District.

E. In the case of a sewer service for an individual builder, the following shall apply:

1. The individual builder shall connect to the sewer service at his sole cost and expense.
2. The sewer facilities shall be installed to the District's specifications and may become the property of the District upon petition by the individual builder or property owner and if accepted by the District.

F. Connection fees shall be tied to the type of use of the premises. A standard unit shall be defined as the wastewater generated by an average single-family residence (SFR), equivalent dwelling unit (EDU), which is located within the District limits.

<u>Type of Premise</u>	<u>Rate</u>
Residential Unit	\$10,000 per unit
Accessory Dwelling Unit -	\$10,000 per unit

1. Any newly constructed attached or detached ADU that is not located within the living space of the existing primary residence or accessory structure and that provides independent living facilities for one or more persons will be charged a

residential connection fee and shall pay. monthly residential sewer fees.

a. *No new connection fee shall be charged to any District customer with an existing building (e.g. barn, outbuilding, or garage) at the time of adoption of this Ordinance amendment that has an existing sewer connection. If, however, the existing building is upgraded to a single-family unit (SFU) or commercial use, monthly sewer fees will apply at the same rate charged units of that type\use.*

2. Any new prefabricated structure(e.g. RV trailer, mobile or not, tiny house) that has utility equipment attached will be charged a new connection fee and shall pay the applicable monthly sewer fees for the type of use.

Multiple Dwelling Unit	\$10,000 per unit
Motel/Motel Units w/o kitchen	33% of Equivalent Res. Units times the number of units. Units shall be considered one room with one or more beds.
Hotel/Motel Units w/kitchen	50% of Equivalent Res. Units w/kitchen times the number of units. Units shall be considered one room with one or more beds.
Mobile Home Park	\$10,000 per unit
Restaurant	\$10,000 per unit
Commercial	\$10,000 per unit. Fee shall be set by the District and based on the projected water usage as it compares to an average residential residence.
Industrial	\$10,000 per unit
All other building & structures w/water	\$10,000 per unit
Commercial, industrial and all other buildings	Set by the Board and based on structures that may generate high waste volumes, projected flow and loading, or impose high loads.

G. Any person or entity found operating any function required above without first securing and paying the required fee shall be required to cease any further efforts. The person or entity must then apply for the required permit The District will then charge twice the normal fee/s plus any costs to the District for said violation.

02.07.080 Additional sewer permit and inspection fees. Application, plan review, permit and inspection fees are established as follows:

A. Any alteration in any building sewer or other sewer or facility covered by an existing permit, which alteration does not reflect an alteration of use, shall require an additional permit, the fee for which shall be fifty dollars (\$50.00), plus the actual costs of inspecting said alteration.

B. Construction of public sewer.

1. An application fee of \$100 per dwelling unit shall be paid by the applicant.

2. The applicant shall deposit an estimated fee to the District to cover the actual costs to plan check and inspect the project. This fee may be paid in two equal installments. The first installment shall be paid when plans are submitted for checking. The balance of the fee shall be deposited prior to the actual start of work. All other District fees shall be paid separately by the applicant. The plan checking and inspection fee deposit shall be determined in accordance with Table 1.

<b>TABLE I</b>	
<b>PLAN CHECK AND INSPECTION FEE DEPOSIT AMOUNTS</b>	
<b>Total Estimated Cost of Improvements*</b>	<b>Percentage of Estimated Cost for Deposit</b>
1. Less than \$ 10,000.00	12%
2. \$10,000.00 to \$ 99,999.99	\$ 1,200 + 8% of amount over \$ 10,000.00
3. \$100,000.00 to \$399,999.99	\$ 8,000 + 5% of amount over \$100,000.00
4. Greater than \$400,000.00	\$16,000 + 4% of amount over \$400,000.00
*Based upon Applicant’s Engineer=s Estimate of improvement costs.	

3. Plan check and inspection deposits shall be placed in a fund and all charges, as deemed necessary by the District for plan checking and inspection shall be charged against that fund. No inspection work or construction work shall be undertaken if the cost of such inspection exceeds the funds remaining in the fund. Whenever the fund is exhausted, the applicant shall deposit additional funds for further inspection work. When the total inspection charges are less than the deposit, the balance will be returned to the

applicant after the improvements have been certified as complete by the District Engineer and all conditions of approval have been met.

C. Renewal or extension of permit. Whenever a permit for sewer installation expires, as provided in Article VII, section 02.07.050, an additional fee of one hundred dollars (\$100.00) shall be paid for a one year extension of the permit for said installation. No extensions will be granted after one extension.

02.07.090 All work to be inspected. All sewer construction work, building sewers and drainage systems shall be inspected by the District inspector to ensure compliance with all requirements of the District. No sewer shall be covered at any point until it has been inspected and passed for acceptance. No sewer shall be connected to the District's public sewer until the work covered by the permit has been completed, inspected and approved by the District inspector. All sewers shall be tested for leakage in the presence of the District inspector and shall be cleaned of all debris accumulated from construction operations. If the test proves satisfactory, the District inspector shall issue a certificate of satisfactory completion.

02.07.100 Notification. It shall be the duty of the person doing the work authorized by permit to notify the District that said work is ready for inspection. Such notification shall be given not less than forty-eight (48) hours before the work is to be inspected. It shall be the duty of the person doing the work to make sure that the work will stand the tests required by the District before giving the notification specified in this section.

02.07.110 Condemned Work. When any work has been inspected and the work condemned and no certification of satisfactory completion given, a written notice to that effect shall be given instructing the owner to repair the sewer or other work authorized by the permit in accordance with the ordinance, rules and regulations of the District.

02.07.120 All costs paid by owner. All costs and expenses incident to the installation and connection of any sewer or other work for which a permit has been issued shall be borne by the owner. The owner shall indemnify the District from any loss or damage that may directly or indirectly be occasioned by the work.

02.07.130 Outside Sewers. Permission shall not be granted to connect any lot or parcel of land outside the boundaries of the District to any public sewer in or under the jurisdiction of the District unless all permitting requirements as defined in Article VII are complied with for any lot or parcel annexed into the District or that the District as agreed to serve.

02.07.140 Encroachment permit. A separate encroachment permit must be secured from the District, or any other entity having jurisdiction, by owners or contractors intending to excavate in a public street for the purpose of installing sewers or making sewer connection.

02.07.150 Indemnification. The Applicant shall indemnify the District and its officers, agents and employees for any injury or death to any person or damage to any property arising during or growing out of the performance of any work by any such applicant. The applicant shall be liable for, and shall save the District and its officers, agents and employees harmless from any liability imposed by law upon the District or its officers, agents or employees, including all costs, expenses, fees and interest incurred in defending same or in seeking to enforce this provision. Applicant shall be solely liable for any defects in the performance of his/her work or any failure which may develop therein.

ARTICLE VIII. SEWER SERVICE RATES AND PROCEDURES

02.08.010 Rate schedule (Resolution 06-2009 10/08/09)

A. Each permittee shall pay sewer service charges in accordance with the amount of sewage from permittee’s property which enters the public sewer, which charges shall be fixed by the Board from time to time by resolution. Said charges may include a standby charge which shall be paid whether the permittee uses the public sewer or not. The sewer service charges shall be set in accordance with the “Revenue Program” for the District, as set forth in Appendix III. Said Revenue Program shall be kept on file and available to the public in the District’s office. Said sewer service charges shall be based on each permittee’s use of said public sewer.

1. The basic sewer service rate per month per equivalent dwelling unit, EDU, (single-family residence or equivalent thereof), may be changed by resolution from time to time by the Board to account for inflation or other factors.

2. Equivalent percentages of the basic service charge for different users will be calculated according to the following table:

Single family residence (1 edu)	100%
Mobile home or trailer (1 edu)	100%
Accessory Dwelling Unit - SFR (1 edu)	100%
Duplex, triples (per edu)	100%
Commercial trailer park (per space)	100%
Apartment (per unit)	100%
Motel, Hotel	Determined on basis of use*
Office establishment	Determined on basis of use*
Commercial establishment	Determined on basis of use*
Restaurant or bar	Determined on basis of use*
Community hall or church	Determined on basis of use*
Gas station	Determined on basis of use*
Schools	Determined on basis of use*
Laundromats	Determined on basis of use*

Industrial	Determined on basis of use*
Vacant lots	Annual Rate of \$100.00
Mixed use Residential\Commercial Structures	Determined based on an evaluation of the mix of uses.

\*To be determined by using an average water usage throughout the months of November thru March and eliminating the high and low month. Divide the calculated flow by the similar average of all the single-family residences (edu) and multiply by the monthly rate for an edu.

\* When Construction begins on a vacant lot, regular monthly billing will begin, using the chart above, the first month following start of construction.

Uses not in current list may be estimated by Murphys Sanitary District for the first year and permanent fee established thereafter.

Rate =  $(\text{Nov.} - \text{Mar. less high \& low}) \times \text{Monthly Rate for an edu}$

New business shall be estimated and adjustment made after the first year of operation.

B. All connections outside the District shall pay a charge that would be payable if the premises were located within the District plus costs incurred by the District that are a direct result of said connection.

02.08.020 Power to inspect premises. In order to effect the powers of this ordinance, and pursuant to Section 6523.2 of the Health and Safety Code of the State of California, the District and its authorized representatives are given the power and authority to enter upon private property during business hours for the purpose of inspection and maintenance of sanitary and waste disposal facilities, including, but not limited to, ascertaining the nature of such premises, the type of activities carried on therein, the number of plumbing fixtures situated therein, and any other facts or information reasonably necessary to ascertain the applicability of any sewer charges to such premises, or the amount of such charges.

02.08.030 Vacancy. No credit, adjustment or refund will be made to any owner because the premises or any part thereof are vacant unless said premises are disconnected from the sewer system.

02.08.040 Refunds. When any refund becomes due and owing by virtue of action of the Board or by virtue of any error made in ascertaining the charge applicable to any customer, the Board is authorized to make payable such moneys from the specific fund established for the deposit of sewer charges.

02.08.50 Collection of sewer service charges. All sewer service charges shall be billed in advance on a monthly basis and collected and deposited in a special fund established and maintained for that purpose.

02.08.060 Due date of sewer service charges. All sewer service charges shall become due and payable as billed. Where service to any premises is commenced by connection between the first and last day of the billing period, charges for such premises for the balance of said period shall be due and payable at the end thereof. In no event shall the charge be less than the charge for one month.

02.08.070 Persons responsible. All sewer service charges shall be billed to the owner of the premises on the date on which such premises are connected to the service area sewer system, or to the successor in interest to such person. It shall be made the duty of all owners and users of all premises to inform the District immediately of all circumstances, and of any change or changes in any circumstances, which will in any way affect the applicability of any charge to premises owned by him/her or the amount of any such charge. The owner of the premises is and shall be responsible for payment of any and all sewer service charges applicable to premises owned by him. By agreement between the District and the owner and a signed application on file, occupants or lessees of the owner's property other than the owner may be billed directly by the District with the owner ultimately liable for any unpaid charges.

02.08.080 Delinquency date. Except as otherwise provided elsewhere in this ordinance, the sewer service charge shall be considered delinquent if not received within twenty-eight (28) days following the date of billing.

02.08.090 Penalties for nonpayment. All delinquent accounts shall be assessed a 10% late fee, and shall accrue for the period of said past due balance and be collected as part of the principle thereof.

## ARTICLE IX. MANAGEMENT AND ENFORCEMENT

02.09.010 General Manager---Enforcement responsibility. The General Manager or designee is charged with the enforcement of all the provisions of this ordinance.

02.09.020 Delinquency – Collection Actions. Upon failure of any person billed or the owner of any premises to pay any sewer service charge prior to delinquency, or if the owner or occupant of any premises violates any other provision of the ordinance, any one or more of the following actions authorized by this section may, or where required by this ordinance must, be taken by the District to enforce such payment:

- A. In each case where any bill for sewer service remains unpaid

after such bill becomes delinquent, and in each case where a violation of any other provision of this ordinance continues for a period of sixty (60) days, the District may disconnect the premises from the sewer system, all subject to the provisions of Article X, section 02.10.030. Whenever premises have been disconnected from the sewer system for non-payment of sewer service charges, such premises shall not be reconnected to the sewer system until all delinquent charges, penalties and all the District's costs of disconnecting and reconnecting have been paid.

B. In each case where premises are disconnected from the sewer system, the District shall cause the County to take or to request any authorized public officer to take such steps as may be legally taken to abate such premises and to prohibit occupancy of such premises until they are reconnected to the sewer system.

C. In each case where all or any part of any bill for sewer service only remains unpaid for sixty (60) days following the delinquent date thereof, the District may cause the General Manager to initiate an action against the person billed for the amount of the delinquent bill, including all basic and monthly penalties, plus court costs, and shall cause the District to prosecute such action to final judgment against the defendant in such action.

D. The District may elect to use the tax roll on which general taxes are collected for the current or delinquent sewer service charges. Charges that remain delinquent and unpaid for a period of 60 days may be collected on the tax roll pursuant to Section 6520.10 of the Health and Safety Code. The amount of any charges for sewer and other services, or either, included in the statement of delinquent and unpaid charges shall be added to and become a part of the annual taxes next levied upon the property for which the sewer service was provided and shall constitute a lien on that property as of the same time and in the same manner as does the tax lien securing the annual taxes. The County shall deduct from the charges collected an amount sufficient to compensate the County for costs incurred in collecting the delinquent charges. The District shall notify the assessee shown on the last equalized assessment roll that whenever charges that are delinquent and unpaid for 60 days or more could become a lien on the property.

E. In the event any charges for sewer and other services remain unpaid, the District may secure the unpaid charges by recording with the county recorder a certificate specifying the amount of charges and the name and address of the person liable for the charges pursuant to Section 6520.12 of the Health and Safety Code. The recordation of the certificate, the amount to be paid together with interest and penalties constitutes a lien upon all real property in the County owned by the person or the person who acquires the property before the lien expires. The lien shall have the force, priority, and effect of a



judgment lien and continue for 10 years from the date of recording unless sooner released, otherwise discharged, or extended by recording a new certificate.

02.09.030 Violations. Any person found to be violating any provision of this ordinance, rule or regulation of the District shall be served by the General Manager or other authorized person with written notice stating the nature of the violation and providing a reasonable time limit for the satisfactory correction thereof, unless the violation is deemed by the District or the County health officer to be a public health hazard, in which event the legal requirement for notice and a period to correct the violation shall be modified. Said time limit shall be not less than two, or more than seven working days. The offender shall, within the period of time stated in such notice, permanently cease all violations.

All persons shall be held strictly responsible for any and all acts of agents or employees done under the provisions of this ordinance, rule or regulation of the District. Upon being notified by the District of any defect arising in any sewer or of any violations of this ordinance, rules or regulations, the person or persons having charge of said work shall immediately correct the same.

02.09.040 Public Nuisance – Abatement. During the period of such disconnection, habitation of such premises by human beings shall constitute a public nuisance, whereupon the District or County may cause proceedings to be brought for the abatement of the occupancy or use of said premises by human beings during the period of such disconnection. In such event, and as a condition of reconnection, there shall be paid to the District or County a reasonable attorney's fee and cost of suit arising in said action.

02.09.050 Infraction. Violation of any provisions of this ordinance shall be punished with a fine not exceeding one hundred dollars (\$100.00) for the first violation, a fine not exceeding two hundred and fifty dollars (\$250.00) for a second violation within a year, and a fine not exceeding five hundred dollars (\$500.00) for a third violation within the period of one year. Each and every connection or occupancy in violation of any provisions of this ordinance shall be deemed a separate violation, and each and every day or part of a day the violation continues shall be deemed a separate offense under this ordinance and shall be punishable as such.

02.09.060 Liability for Violation. Any person violating any of the provisions of this ordinance, rules or regulations of the District shall become liable to the District for any expense, loss or damage occasioned by the District by reason of such violation.

## ARTICLE X. MISCELLANEOUS

02.10.010 Protection from damage. No person shall maliciously, willfully, or negligently break, damage, destroy, uncover, deface or tamper with any structure, appurtenance or equipment which is part of the District's sewer works. Any person violating this provision shall be subject to the penalties provided by law.

02.10.020 Powers and authorities of inspectors. Any duly authorized employee or agent of the District shall be permitted to enter in and upon any and all buildings, industrial facilities and properties for the purposes of inspection, re-inspection, observation, measurement, sampling, testing or otherwise performing such duties as may be necessary in the enforcement of the provisions of the ordinance, rules and regulations of the District.

02.10.030 Severability. If any section, subsection, sentence, clause or phase of this ordinance or the application thereof to any person or circumstances is for any reason held to be unconstitutional or invalid, such decision shall not affect the validity of the remaining portions of this ordinance or the application of such provision to other person or circumstances. The Board hereby declares that it would have passed this ordinance or any section, subsection, sentence, clause or phrase hereof irrespective of the fact that any one or more sections, subsections, sentences, clauses or phrases be declared unconstitutional.

02.10.040 Inapplicability of inconsistent ordinances. All other District ordinances concerning the sewer system, sewer service charges, and sewer connection, permit and inspection fees are hereby repealed. All existing sewer service fees, sewer connection fees, permit fees and inspection fees as set forth in any of those ordinances and resolutions which exist as of this date shall remain effective until the new service fees, sewer connection fees, permit fees and inspection fees become effective by virtue of the ordinance. Future connection fees, sewer service fees, permit fees and inspection fees may be adopted by Resolution of the Board.

This Ordinance shall take effect and be in force on the 27<sup>th</sup> day of September 2019, 2019 by the following vote:

AYES: J. Fontana, S. Gonzales, A. Moore, T. Owens

NOES: 0

ABSENT: L. Scheller

\_\_\_\_\_  
Vice President, Board of Directors  
MURPHYS SANITARY DISTRICT

Attest:

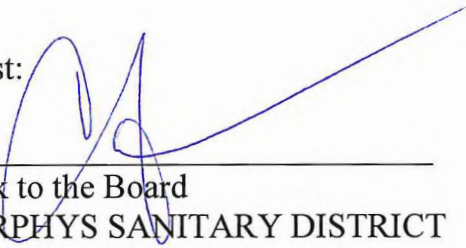
  
\_\_\_\_\_  
Clerk to the Board  
MURPHYS SANITARY DISTRICT

**Proof of Publication of**

**(2015-5 C.C.P.)**

Public Notice  
Murphys Sanitary District  
Ord 2 Amendments

NOTICE of Adoption  
Murphys Sanitary District Use Ordinance No. 2 Amendments  
02.08.010 Rate Schedule  
02.07.070 Connection Fee

The amendments to the District's Use Ordinance added newly constructed accessory dwelling units to the District's rate schedule for both connection and monthly sewer rates at the same rates as single family residences. The amendments also allow the District to determine the mixed use residential/commercial structures, depending on an evaluation of the mix of uses. The amendments would also make additional non-substantive clarifying and conforming changes to the Use Ordinance. To view the Use Ordinance with the adopted changes in its entirety, please visit our website: [murphysd.org](http://murphysd.org) or call the office 209 728-3094 to request a copy.

The Ordinance amendments were adopted by the Murphys Sanitary District Board of Directors by the following vote at a Public Hearing held on September 12, 2019:

Joseph Fontana	Yes
Steve Gonzales	Yes
Ashley Moore	Yes
Travis Owens	Yes
Lydia Scheller	Absent with Notice

The Ordinance changes will be effective seven (7) days from the date of this publication.

**This space is for the County Clerk's Filing Stamp**

STATE OF CALIFORNIA,

County of Calaveras.

I am a citizen of the United States and a resident of the county aforesaid; I am over the age of eighteen years and not a party to or interested in the above matter. I am the principal clerk of the printer of the Calaveras Enterprise, a newspaper of general circulation, printed weekly, in the City of San Andreas, California, County of Calaveras, and which newspaper has been adjudged a newspaper of general circulation by the Superior Court, of the County of Calaveras, State of California; that the notice of which the annexed is a printed copy (set in type not smaller than nonpareil), has been published in each regular and entire issue of said newspaper and not in any supplement thereof on the following dates; to-wit:

**September 19, 2019CE**

I certify (or declare) under penalty of perjury that the foregoing is true and correct.

**Dated the 17th of December, 2019**



Signature – Corissa Davidson

**CALAVERAS  
ENTERPRISE**

15 North Main Street  
P.O. Box 1197, San Andreas, CA 95249-1197  
(209) 754-3862 - FAX (209) 754-1805

**PROOF OF PUBLICATION**

APPENDIX I  
MURPHYS SANITARY DISTRICT

**Section 1 – General Requirements for Sanitary Sewer Installations**

**1.01 General**

These specifications and all Ordinances of the Murphys Sanitary District shall be considered as part of this section, and all plans, profiles, cut sheets, easements, documents, and details of construction shall conform to the standards established in these Improvement Standards and Specifications.

Reference is also made to the Uniform Plumbing Code currently in effect regulating the installation of building sewers and house drainage systems, copies of which are on file in the office of the Building Department.

Further reference is made to the Health and Safety Code and Title 17 of the Administrative Code of the State of California relating to sewers and sewer districts. All work contemplated in the Murphys Sanitary District shall comply with the applicable regulations in these codes.

Prior to the completion of construction of sanitary sewers, the owner or his engineer shall make such arrangements as may be necessary for the operation and maintenance of all sewer facilities including treatment plants and lift stations. Operation and maintenance shall conform to all applicable laws and regulations of the Murphys Sanitary District, the County of Calaveras, and the State of California.

**1.02 Right of Way**

All public sewers shall be in easements or rights of way dedicated to the public. The minimum width of easement shall be twenty (20) feet.

The easement shall be centered on the sewer line unless otherwise permitted by the District Engineer.

Right of way maps shall be submitted along with construction plans showing the exact location and dimensions of all easements which must pass through private property. The location and width of easements shall be subject to the approval of District Engineer.

### **1.03 Line Size and Connection Policy**

House connection lines may be connected to “live” public sewers. Actual tapping of the “live” public sewer shall be done by District forces.

Single house building sewers shall be a minimum of four (4) inches in diameter.

Joint use (multiple buildings with same side sewer) will not be permitted, unless approved by the Operations Manager on a one by one basis.

In all new subdivision work, the lateral sewers shall be installed at the time the public sewer is constructed. Each lateral sewer shall be referenced to the plan stationing and shall end at the property line with a cleanout.

### **1.04 Design Criteria**

- A. Population density within a sewer service area shall be determined on the basis of actual count, character of proposed development (present and future), and the master plan of land use and zoning. All sewers shall be designed to carry peak flows without surcharging the manholes.

For estimating purposes, the dwelling unit shall consist of 2.5 persons. Flow estimates for industrial and commercial land uses shall require individual study and approval. Discussion of parameters with the District Engineer is advised prior to the study.

Design population estimates including equivalent population for schools, commercial, and industrial uses, shall be indicated on the set of plans submitted for approval.

- B. Design sanitary flow shall be two (2) times the average flow of 140 gallons per capita per day.
- C. Infiltration allowance shall be calculated on the basis of fifty (50) gallons per mile per day per inch diameter of pipe.
- D. All public sewers shall be designed flowing full without head.
- E. Sewer velocity shall be not less than two (2) feet per second when flowing full and shall be restricted to ten (10) feet per second unless special pipe or controls are approved by the District Engineer.
- F. Diameter of gravity sewers shall be determined by the type of pipe and the pipe manufacturer’s recommendation.

- G. Special design problems involving siphons, pumps, force mains, non-residential connections, or other unusual features not covered herein, will require individual study and approval by the District Engineer.

### **1.05 Sewer Location in Streets and Roads**

Where sewer lines are installed in street or road rights of way, they shall be installed between present or future gutters in the roadway as follows:

- A. Whenever possible, all public sewers shall be located five (5) feet southerly or easterly of the center line of the street.
- B. The entire sewerage system to be located within roads or easements shall be designed so that all existing improvements of other utilities will be cleared by the sewer improvements, structures, and laterals, by a minimum of twelve (12) inches.
- C. No sanitary sewer, including house connection, shall be located within fifty (50) feet of a water well, and any sewer between fifty (50) feet and one hundred (100) feet of a well shall be constructed of ductile iron pipe with rubber gasket joints.
- D. Curvilinear alignment of sanitary sewers will be permitted under the following conditions:
  - 1. Minimum radii for pipes to 10" I.D. – 200'.
  - 2. Minimum radii for pipes 12" to 15" I.D. – 300'.
  - 3. In no case will the curvilinear alignment maximum radii exceed that of the pipe manufacturer's specification.
- E. Separation between potable water and storm drain piping shall meet or exceed the minimum requirements of the State of California Department of Public Health.

### **1.06 Sewer Structures**

#### A. Manholes

Manholes shall be placed at all intersections of sewer lines other than house connection sewers, at all vertical or horizontal angle points, and at intervals not greater than three hundred (300) feet.

Where sewers are installed with curvilinear alignments, the distance between manholes shall not exceed three hundred (300) feet. Where the alignment consists of combinations of compound curves, reverse curves, and curves connected with short tangents, the total distance between manholes along such combinations shall not exceed three hundred (300) feet.

Drop manholes will not be permitted, unless approved by the District Engineer.

The angle of deflection between incoming and outgoing lines in a manhole shall not be greater than ninety (90) degrees.

B. Clean Outs

A clean out shall be placed at least fifteen (15) feet beyond the property line projection at the end of each public sewer.

A clean out may be used in lieu of a manhole for any stub line with a length of one hundred (100) feet or less. Any line more than one hundred (100) feet in length shall have a manhole at the end. Public sewers installed in a subdivision or other development for future extensions shall have a clean out at the end if there are any house connections attached to it, and it is not over two hundred (200) feet in length. Lines longer than two hundred (200) feet shall terminate in a manhole with a five (5) foot minimum stub and plug for future extensions installed at the time the manhole is constructed.

C. Temporary Plugs

Temporary plugs may, with approval of the District Engineer, be used at the end of lines which are to be extended within one (1) year of completion.

D. Pressure Frame and Covers

Pressure (water tight) frames and covers shall be installed where drainage conditions may cause storm waters to inundate sewer structures.

E. Remodeling Structures

All structures to be remodeled shall comply with these standards. Any remodeling of any structure shall be specified and/or detailed on the plans and approved by the District Engineer prior to any remodeling.

F. Special Instructions

Manholes over large pipes, special junction boxes, siphons, pedestals, trestles, traps, pumping systems, force main, bridges, and other unusual structures require specific design approval by the District Engineer.



## **1.07 Construction Engineering**

- A. The Inspector and/or Engineer shall refer to the Special Provisions of the particular job for all details of Construction which may refer to these standards or other recognized standards of construction.
  
- B. Marking
  - 1. Where curbs and gutters or sidewalks are part of an improvement, each lateral sewer shall be permanently located by imprinting an “S” (2” size or larger) on the curb vertically above the side sewer. Responsibility for providing the marking and for its accuracy shall rest with the Contractor.
  - 2. Engineer’s station, structures, and wyes shall be marked on the cut stakes in advance of trenching.
  - 3. In subdivisions, prior to installation of a lateral sewer, the lot corner nearest the lateral sewer, shall be located, staked, and flagged in the field.
  - 4. The end of the house connection laterals shall be marked with a clean out.

## **1.08 Record Plans (As Constructed)**

The Project Design Engineer shall keep an accurate record of all approved deviations from the plans. These are to be utilized in correlation with the Inspector’s plans for preparing a complete and accurate set of Record Plans for the permanent records of the District.

The drawings for the project shall be returned to the Project Design Engineer upon completion of work and all construction changes shall be made thereon and the drawings returned to the District.

## **Section 2 – Construction Requirements for Sanitary Sewer Installations**

### **2.01 Alignment and Grade Control**

The grade and alignment of the pipe shall be maintained by use of a method approved by the District Engineer in advance of the construction. The proposed method shall be submitted for review prior to commencing the work.

Horizontal alignment shall be such as to maintain a true line between manholes. Any deviation there from must meet the approval of the District Engineer.

Unless otherwise approved by the District Engineer, line and grade shall be staked by a registered civil engineer or licensed land surveyor. Staking shall be on 50 foot intervals, minimum, for straight lines and 25 foot intervals for horizontal and vertical curves. The District Engineer may at any time check the alignment and grade from staking. Contractor shall take appropriate means to preserve, as is practicable, all stakes, bench marks, and control used in the setting of alignment and grade. Where, in the judgment of the District Engineer, the loss of stakes and/or other reference points from whatever cause, requires restaking, such restaking shall be performed when and as directed by the District Engineer and shall be done at the cost of the owner.

**2.02 Sewer Pipes**

- A. Minimum pipe size for public sewers shall be six (6) inches.
- B. The minimum acceptable slopes for sewer pipe sizes are as follows unless flatter slopes are specifically approved by the District Engineer:

<u>Pipe Size</u> <u>In Inches</u>	<u>Minimum Slope Ratio</u> <u>In Feet Per Ten Feet</u>
6	.005
8	.0035
10	.0025
12	.002
15	.0015
18	.0012
4 (Building Sewer Line Only)	.020

- C. Minimum pipe cover shall be three (3) feet except as may be classified as follows:
  - 1. Two sack cement slurry cover shall be used when total cover over public sewers is less than three (3) feet, or when other special conditions exist.
  - 2. Two (2) to three (3) feet of cover may require the use of approved bedding encasement or extra strength pipe as directed by the District Engineer.
  - 3. Less than two (2) feet of cover shall require concrete encasement of extra strength pipe as directed by the District Engineer.
  - 4. All pipe lines shall be designed and constructed to a safety factor of 1.5. The Project Design Engineer, during design, shall consider impact and dead loads imposed upon the pipe both during construction and after construction. The construction plans shall show the maximum permissible trench width at the top of the pipe which shall be predetermined by the Project Design Engineer.

A note shall be placed on the plans as follows: *“For trenches in excess of the width as shown on the plans, the Contractor shall adequately reinforce the pipe at his expense upon written approval by the District Engineer.”*

### **2.03 Kind of Pipe**

1. Polyvinyl chloride pipe shall be of a type as manufactured under the brand name “Ring Tite PVC Pipe” or approved equal. Pipe shall be polyvinyl chloride plastic gravity sewer pipe with integral wall, bell, and spigot O-ring type joints. Pipe and fittings shall be the extra strength minimum of SDR 35 of the requirements of ASTM designation D-3034. All fittings such as wyes, tees, bends, reducers, and connections shall be the same material and manufacturer as the pipe. Rubber rings shall conform to ASTM designation D-1869. No solvent cement joints shall be used.

All PVC shall have a home mark to indicate full penetration when the joint is made. PVC and fittings shall not be stored with direct exposure to sunlight for any extended period of time as determined by the District Inspector. If storage for a long time is necessary, pipe and fittings shall be covered with opaque material providing for air circulation, or otherwise protected in a manner approved by the District Engineer.

2. All force main pipe shall be a minimum 125 psi PVC water pipe, ASTM designation D-2241, SDR 32.5 with rubber O-ring type joints. Rubber rings shall conform to ASTM designation D-1869. No solvent weld joints shall be used. Storage specifications apply as in PVC above. The District Engineer may require C-900 PVC pipe where circumstances warrant.
3. Ductile iron pipe shall be Class 50.

### **2.04 Standard Manholes**

All manholes shall be of concrete construction and shall conform to the standard details unless otherwise specified. The manhole base shall be pre-cast, conform to ASTM C-470 and shall be placed in accordance with the plans, these specifications, and District Improvement Standards. (See District Standard Detail, SS-2, "Standard Type A Manhole" at the back of these specifications.) Control of water in the manhole excavation shall be to the satisfaction of the Engineer. Precautions shall be taken to assure that sewer pipe entering and leaving the manholes does not move from the installed alignment and grade. Flex connectors at the inlet and outlet of sewer manholes shall comply with ASTM C-923. Sufficient material shall be placed on said sewer lines to prevent such movement. Manhole bottom area shall be compacted to 95% relative compaction prior to placing pre-cast base. Appropriate plugs, as approved by the District Engineer, shall be placed in the ends of the pipes in order to prevent concrete from entering the lines during the manhole pour. In case of straight through lines, the pipe

may be laid through the manhole excavation with the base being poured around the pipe. The upper half of the pipe shall then be cut out to form the channel in an approved method.

Care should be taken to set the manhole barrels at the appropriate time during the cure of the concrete to insure proper penetration and allow for sufficient clearance between the bottom of the barrel and top of the pipe. Initial setting and removal of barrels or rings, or the use of a ring form to make the indentation in the base is subject to approval by the District Engineer.

Sufficient care should be taken during the manhole pour operation to observe the rate of cure of concrete and to properly work the surfaces and channels so as to arrive at the required shapes and surfaces and avoid poor results. The channels shall be shaped in flowing curves as indicated on the drawings to insure proper hydraulic characteristics for the flow of sewage. A smooth, clean, hand-rubbed finish shall be given to the surfaces of the manhole base and to any joint mortar work. Transitions between different sizes of pipes shall be smooth and regular. Excessive concrete, mortar or improperly shaped or surfaced channels shall be chipped back and built up again to insure the proper shape and surface. All cracks, joints, holes, etc., shall be sealed by mortar, sealing compounds or dry pack as approved by the District Engineer to insure water tight manholes with workmanlike appearance.

Care shall be taken in setting of barrels, tapered sections, and risers to achieve good elevation control so that no more than 12 vertical inches of grade rings are necessary to adjust the level of the manhole castings (12 inch maximum between top of tapered section and bottom of manhole casting).

Backfill shall be placed uniformly around the outside of the manhole so as to not create differential forces and the possibility of dislodging the manhole sections.

## **2.05 Excavation**

Except by specific approval of District Engineer, no more than 300 feet of open trench shall be excavated in advance of laying of the pipe. Not more than 50 feet of trench excavation shall remain unbackfilled at the end of each day=s work. The remainder of the trench shall be backfilled, compacted, and open to traffic where applicable. Should open trench be determined to be a safety hazard by the District Engineer, all trench excavation shall be backfilled at the end of each day=s work, or all open trenches shall be covered by means approved by the District Engineer.

All crossings of State highways and County roadways are to be done in compliance with the appropriate permit process.

Width of trench shall be uniform from top to bottom and shall be a minimum of 6" wider than the external diameter of the pipe. The maximum width of the trench measured at the

top of the pipe shall not exceed the external width of the pipe plus 12 inches exclusive of bells, collars, and fittings.

Stripping of top soil and separate storage thereof will be required in areas where it is deemed necessary by the District Engineer to preserve the quality of top soil. Stones shall be removed as necessary to avoid point bearing.

Shoring of trenches shall be in accordance with appropriate State and Federal safety regulations and the dictates of good construction practice. Safe access to the trench for inspection purposes shall be provided at all times. The requirements of the California Division of Industrial Safety shall be complied with. Instructions or lack thereof from the District Engineer or his representative in no way waives the Contractor=s responsibility with regard to safety.

The depth of the trench shall be in accordance with the lines and grades shown on the plans with proper allowance for bedding and thickness of pipe and for the type of fittings specified. Any portion of the trench excavated below the proper grade shall be backfilled with approved bedding material and compacted to 95% relative compaction at the Contractor=s expense and at the direction of the District Engineer. All areas of unsuitable material required by the District Engineer to be removed shall be replaced in the same manner.

Removal and disposal shall be required of all water entering the excavation. Disposal of water shall be done in a manner to prevent damage and nuisance to adjacent properties or to the public. Sufficient pumping equipment shall be provided in a manner so as to maintain the trench in a dry condition during the bedding and initial backfilling of pipe. Appropriate precautions shall be taken to prevent drainage water from entering the sewer line being constructed.

## **2.06 Bedding**

Bedding for the pipes shall be of a granular material appropriate to the conditions present in the construction. Depending on said conditions, native soil, clean sand, crushed or pit run gravel, pea gravel or road base may be required for pipe bedding. Type, method of placement, and preparation of bedding shall be approved in advance of the construction by the District Engineer and any changes necessitated by the work or available supply of materials shall be approved by the District Engineer. A minimum of six inch (6”) compacted depth of bedding shall underlie the pipe in all cases. Bedding shall be placed and shaped to fit the underside of the pipe barrel with excavation made for bells or pipe couplings. Compaction shall not be less than 95 percent.

## **2.07 Pipe Installation**

The pipe shall be laid in conformance with ASTM D2321 and in strict conformity with the prescribed alignment and grade as staked. The pipe shall be brought to the site of work by a manufacturer=s approved method. Pipe laying shall proceed upgrade with the

bell ends of the pipe placed upstream. Each section of pipe shall be laid true to line and grade in such a manner as to form a water tight concentric joint with the adjoining pipe. The interior of the sewer shall be kept clear of all dirt and debris during the work process.

All pipe laying and joining, including the maximum deflection of joints in curved alignment shall be in accordance with the pipe manufacturer's specifications and as directed by the District Engineer.

Bedding shall be shaped to fit the barrel of the pipe and give uniform support throughout its length. In the case of installing small diameter pipe, where practicable, the bedding may be shaped by lifting and dropping one end of the pipe in order to form the bed shape as described. Pipe bedding should be excavated from beneath the bell ends or couplings of the pipe so as to avoid any bridging effect. No wedging or supporting of the pipe with wood or any other type of material than the approved bedding shall be permitted.

Initial backfill shall be placed in an approved manner so that the bottom one-third of the pipe rests on a dense compacted bed of approved granular material. Slicing with a shovel tip, tamping with a T-bar, compaction by foot or other approved mechanical equipment may be used to meet such requirements. In case of light weight pipe (PVC) sufficient material must be placed on the pipe to keep it from moving out of line and grade.

Concrete encasement of the pipe may be required by the District Engineer when special circumstances warrant.

## **2.08 Backfill**

Following the completion of the initial backfill phase, approved backfill material shall be placed and compacted to a depth of 12 inches above the top of the pipe with Class 1 backfill (as defined in Caltrans Standard Specifications Section 25, Aggregate Subbases, Section 1.02A) unless otherwise approved by the District Engineer and shall be compacted to 95 percent. Compaction shall be by approved means. Backfill material shall be deposited in layers not exceeding 8". Each layer shall be watered or dried as required to bring the soil as close as practical to the optimum moisture content for proper compaction. Backfill above the 12 inch point (pipe zone) shall be of suitable material placed and compacted by approved methods depending on the location and the jurisdiction of agencies controlling the surface of the work area. Backfill shall be placed in a manner so as not to damage the pipe line. The size and nature of rock, if any, being placed in the trench backfill is subject to approval of the District Engineer. In no case shall roots, vegetable matter, or otherwise deleterious material be placed in the trench backfill. Each layer of backfill above 12" within public streets shall have a relative compaction of 95%. Each layer above 12" and outside street rights of way shall have a relative compaction of 90%.

## **2.09 Installation of Casings, Boring and Jacking**

In case of installation of sewer line in a casing, whether by trenching methods or by boring and jacking, the grade of the installed casing shall be checked with regard to the design slope of the sewer being installed. The sewer line shall be installed by the method outlined in the Johns-Manville Sewer Installation Manual, latest edition, as amended by specific pipe manufacturer's recommendations, and approved by the District Engineer.

The pipe skids shall be shaped and installed in a manner so as to compensate for any misalignment or grade problems in the installed casings. All procedures and equipment used in the installation of a sewer in the casing shall be subject to prior review and approval of the District Engineer. Any filling, sacking, drainage and protection of the casing ends shall be as directed by the District Engineer.

All requirements of agencies having jurisdiction over the street or other type of embankment through which the casing is placed, shall be observed.

## **2.10 Cleanup**

During the progress of the work the Contractor shall maintain the entire job site in a clean and orderly condition as required by all agencies having jurisdiction. The Contractor shall promptly attend to the concerns of any persons having contact with the work and shall repair or replace any damage caused by his operation as directed by the District Engineer.

## **Section 3 – Testing Requirements for Sanitary Sewer Installations**

### **3.01 Pipe Line Testing**

Gravity sewers and manholes shall be initially tested by the Contractor for tightness after they have been completed and backfill has been placed.

All tests shall be witnessed and approved by the District Engineer or designee. Tests shall be made on each section from one manhole or test tee to the next. Water, air, and equipment for tests shall be furnished and paid for by the Contractor.

Air test for gravity pipe sewer lines shall be performed in accordance with the following:

Before this test is performed, all surface work and final paving must be complete prior to final flushing-balling and all testing.

The Contractor shall furnish an inflatable rubber ball of a size that will inflate to fit snugly into the pipe to be tested. The ball may, at the option of the Contractor, be used without a tag line; or a rope or cord may be fastened to the ball to enable the Contractor

to know and control its position at all times. The ball shall be placed in the last cleanout or manhole on the pipe to be cleaned, and water shall be introduced behind it. The ball shall pass through the pipe with only the force of the water impelling it. All debris flushed out ahead of the ball shall be removed at the first manhole where its presence is noted. In the event cemented or wedged debris, or a damaged pipe shall stop the ball, the Contractor shall remove the obstruction.

Immediately following the pipe cleaning described, the pipe installation shall be tested with low pressure air. Air shall be slowly supplied to the plugged pipe installation until the internal air pressure reached 4.0 pounds per square inch greater than the average back pressure of any ground water that may submerge the pipe. At least two minutes shall be allowed for stabilization before proceeding further. The pressure at the beginning of the test shall not be less than 3.5 psi.

The rate of air loss shall then be determined by measuring the time interval required for the internal pressure to decrease .5 psi per square inch.

The pipeline shall be considered acceptable, when the time interval for the decrease in pressure exceeds that shown in the table below:

<u>Pipe Size (inches)</u>	<u>Time (in seconds)</u>
6	185
8	245
10	306
12	370
15	460
18	550
24	735

If leakage is greater than that specified above, the defective joints shall be located and repaired until the leakage is within the specified allowance, without additional cost to the District. Should any repairs to sewer system be necessary, then all surface work and paving repaired must be completed prior to re-test and all costs associated with repairs, surface work, and repaving shall be borne by the Contractor.

### **3.02 Manhole Testing**

Manhole testing shall be by vacuum or water test.

Manholes water tested shall have suitable plugs in the inlet and outlet lines and shall be filled with water to the top of the casting. A one hour maximum absorption period may be required following which the testing of any leakage shall be observed. Maximum leakage shall be determined by the following formula:



LEAKAGE GPM = .001 (Manhole depth) (head above invert or above prevailing ground water\*) 2  
\*Whichever is lesser.

EXAMPLE: For a 6 foot deep manhole with dry conditions

$$\text{Leakage} = .001 (6) (6) 2 = .0147 \text{ GPM}$$

Using 7.48 G/CF and 1728 CI/CF the drop in inches can be easily calculated and measured from the casting rim.

If the manhole leakage exceeds the allowable amount, the manhole shall have failed the test and the Contractor shall repair and retest the manhole to the District Engineer's satisfaction.

Manholes tested by vacuum may be allowed by the District Engineer as follows:

All lift holes and inside and outside joints shall be plugged with an approved non-shrink grout. All pipes entering the manhole shall be plugged, taking care to securely brace the plug from being drawn into the manhole. The test head shall be placed at the inside of the top of the cone section and the seal inflated in accordance with the manufacturer's recommendations. A vacuum of ten inches (10") of mercury (approximately five (5) psi) shall be drawn and the vacuum pump shut off. With the valves closed, the time shall be measured for the vacuum to drop to nine inches (9").

The manhole shall pass if the time is greater than:

60 seconds for 48" diameter manholes

75 seconds for 60" diameter manholes

90 seconds for 72" diameter manholes

If the manhole fails the initial test, necessary repairs shall be made with a non-shrink grout while the vacuum is still being drawn. Retesting shall proceed until a satisfactory test is obtained.

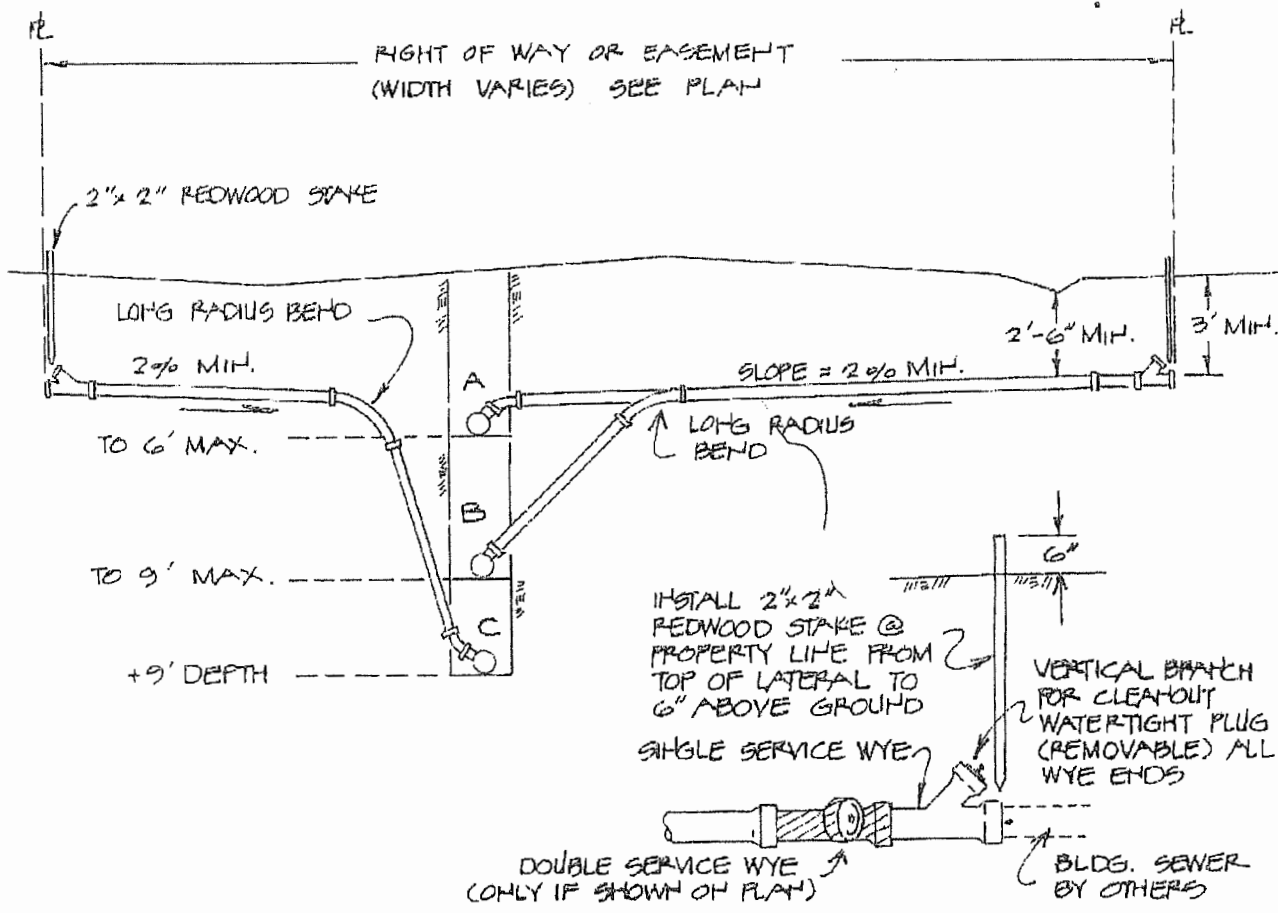

**SERVICE ELEVATION**

\* PLACE CONCRETE 12" WIDE OR WELL COMPACTED BEDDING MATERIAL 18" WIDE UNDER WYE BRANCH AND FITTINGS, AND UNSUPPORTED PIPE. WHEN BEDDING MATERIAL IS USED, PLACE ADDITIONAL MATERIAL TO TOP OF BEND, THE FULL WIDTH OF THE TRENCH.

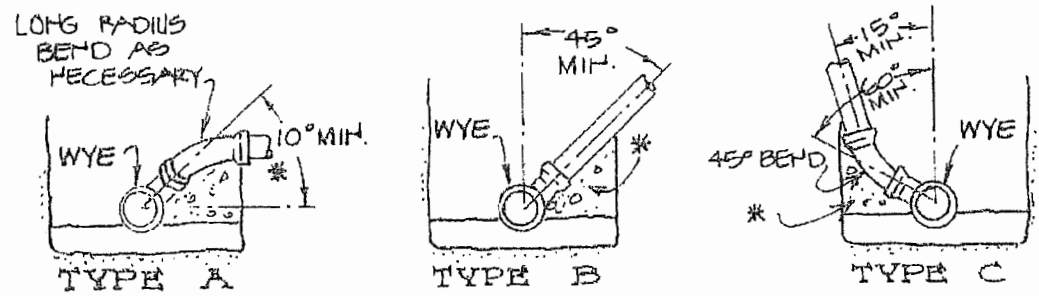

**CONNECTION DETAILS**

MURPHYS SANITARY DISTRICT

SEWER SERVICE  
LATERALS

N.T.S.

			SS-1
	4/29/09	G.G	
REV.	DATE	BY	

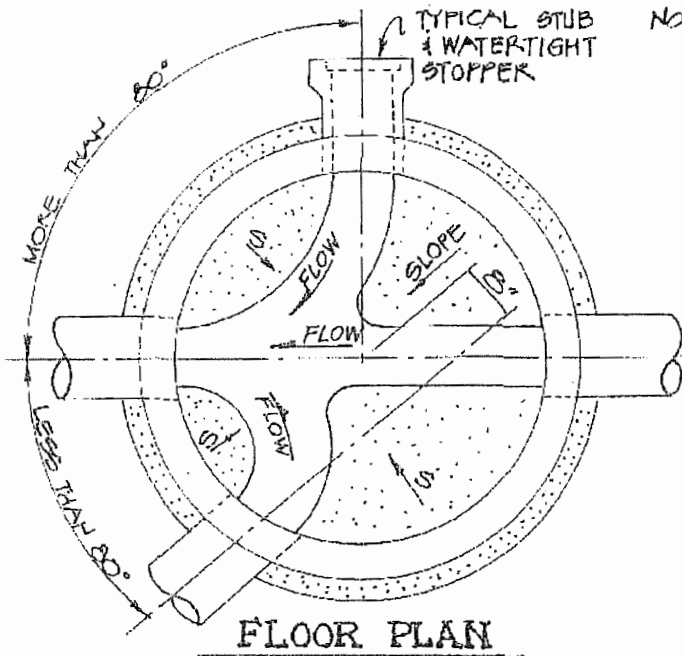

FLOOR PLAN

- NOTES: ① REINFORCED CONCRETE GRADE RINGS, CONES, PIPE RISERS OR APPROVED PRECAST MANHOLE SECTIONS SHALL CONFORM TO CURRENT A.S.T.M. SPEC. Fc. C-478.
- ② SELECT IMPORT MATERIAL, 100% PASSING 3/4" SIEVE & 50% MINIMUM SAND EQUIVALENT.
- ③ ENCASEMENT CONCRETE SHALL BE POURED AGAINST UNDISTURBED EARTH.
- ④ ALL INLETS AND OUTLETS FROM MANHOLE STRUCTURES SHALL HAVE A FLEXIBLE JOINT WITHIN 2 FEET OF THE STRUCTURE.

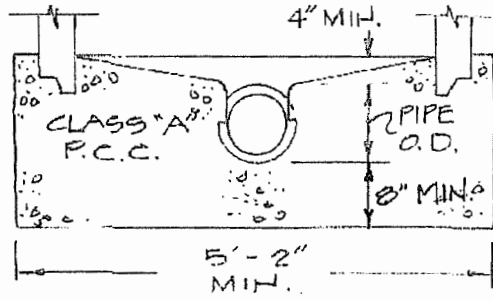

SECTION A-A

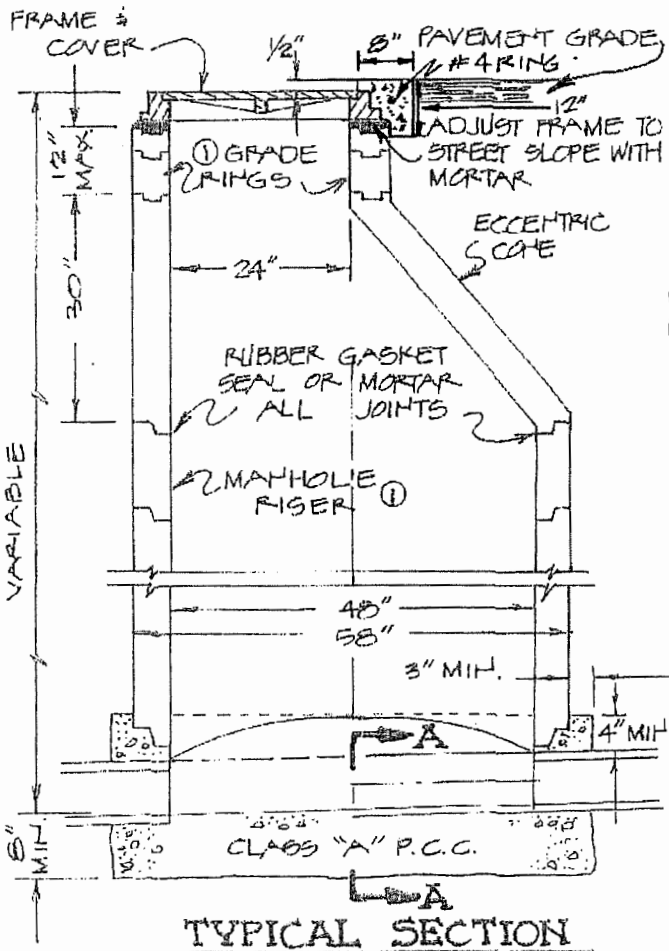

TYPICAL SECTION

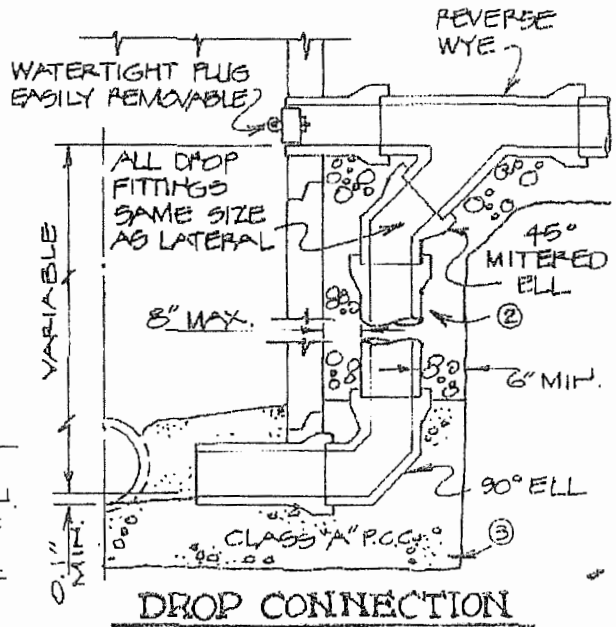

DROP CONNECTION

MURPHYS SANITARY DISTRICT  
 STANDARD TYPE "A"  
 MANHOLE  
 N.T.S.

			SS-2
	4/29/09	G.G	
REV.	DATE	BY	

NOTE: REINFORCED CONCRETE GRADE RINGS, COES, PIPE RISERS OR APPROVED PRECAST MANHOLE SECTIONS SHALL CONFORM TO CURRENT A.S.T.M. SPEC. No. C-478

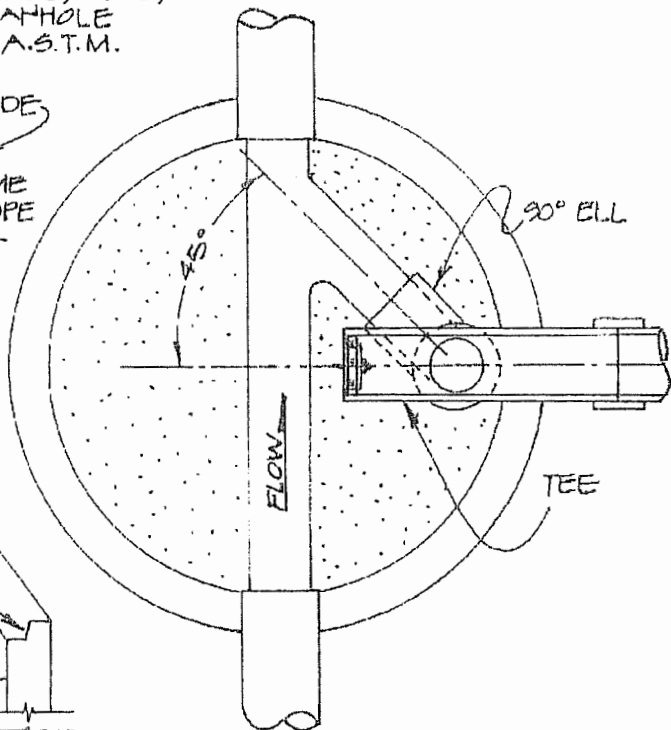
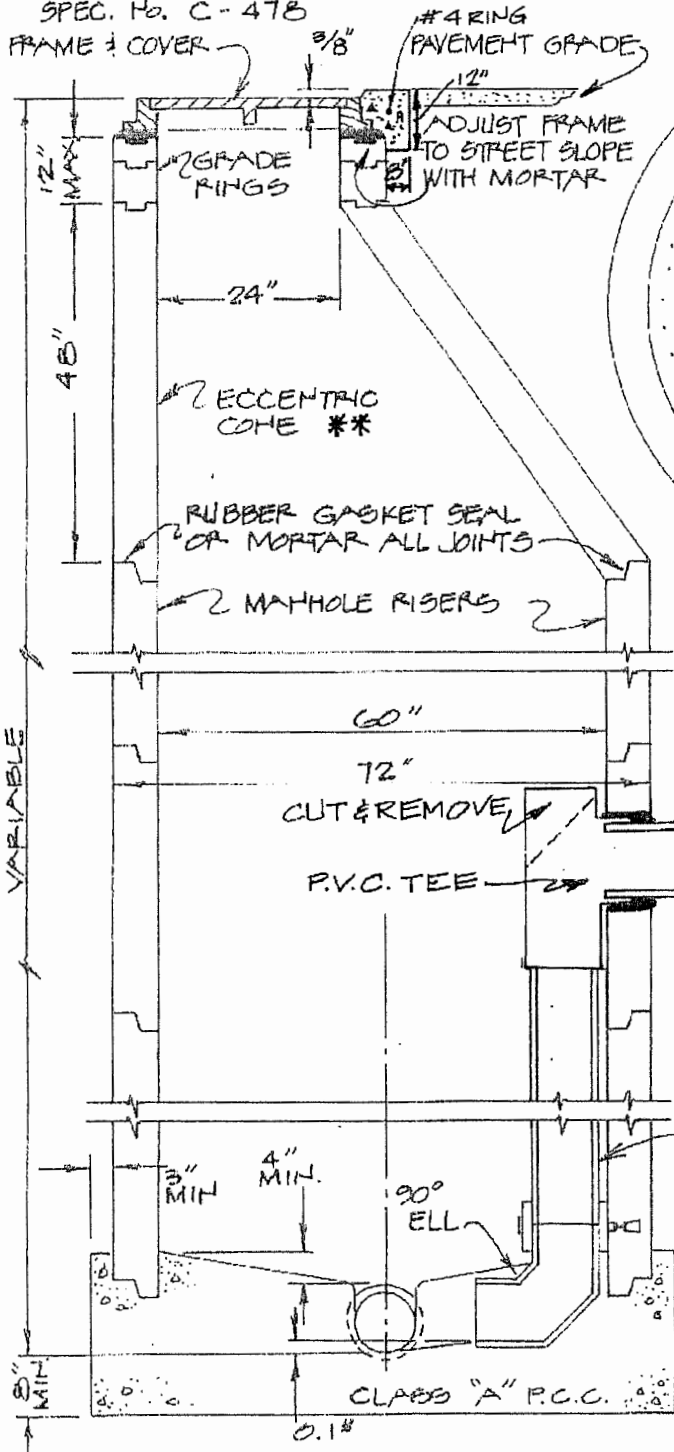

FLOOR PLAN

ALL INTERIOR DROP CONNECTION PIPING & FITTINGS SHALL BE SIZED TO MATCH INLET. \*

\*\* ECCENTRIC COE SHALL BE ORIENTED WITH VERTICAL SIDE DOWN STREAM.

TYPICAL SECTION

MURPHYS SANITARY DISTRICT  
 STANDARD TYPE "B"  
 MANHOLE  
 N.T.S.

			SS-3
	4/29/09	G.G	
REV.	DATE	BY	

TURN ELL TO DIRECTION OF FLOW

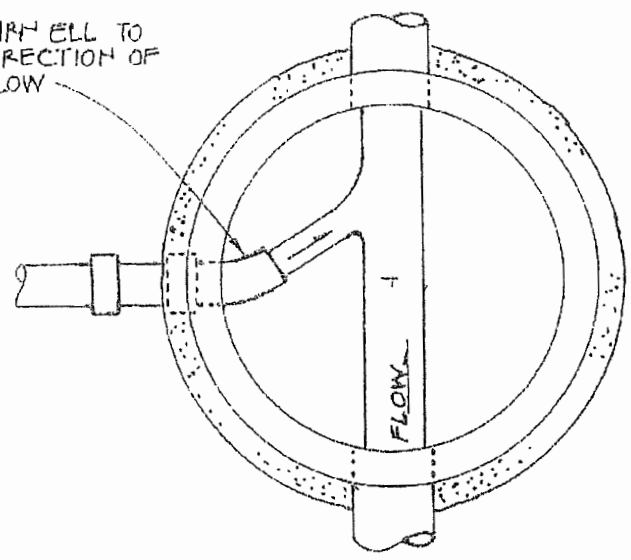

**PLAN**

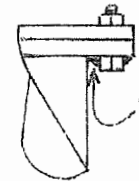

WELD BOLT HEAD TO BOTTOM OF FLANGE

**FLANGE DETAIL**

PROVIDE SMOOTH TRANSITION BETWEEN INVERT OF INLET AND OUTLET OF PIPES.

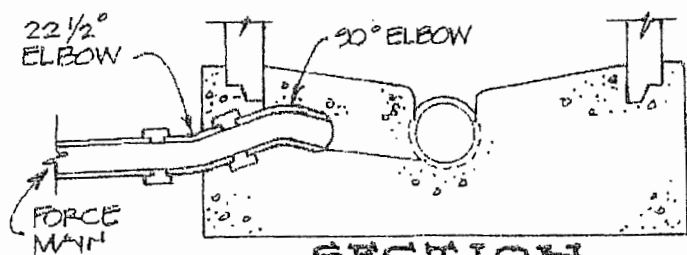

**SECTION OUTLET CONNECTION AT MANHOLE**

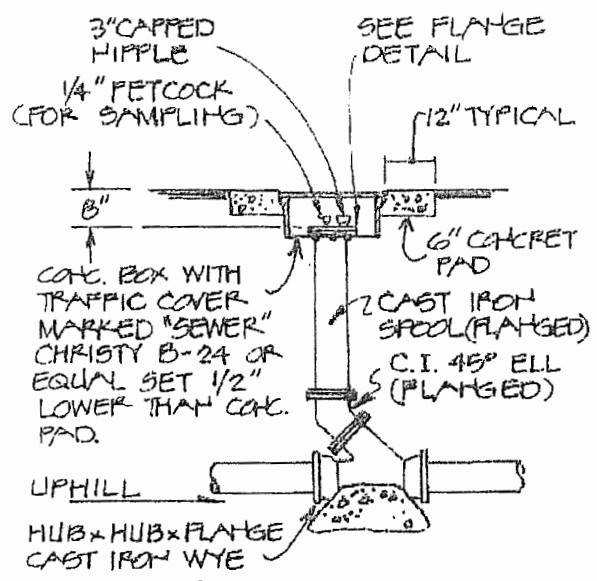

**FLUSHING BRANCH ASSEMBLY**

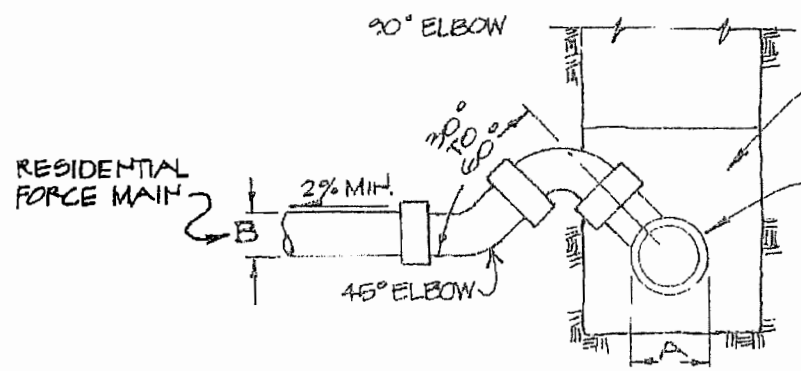

**SERVICE LATERAL TO GRAVITY MAINLINE**

MURPHYS SANITARY DISTRICT  
**STANDARD FORCE MAIN DETAILS**  
 N.T.S.

	4/29/09	G.G
REV.	DATE	BY

SS-4

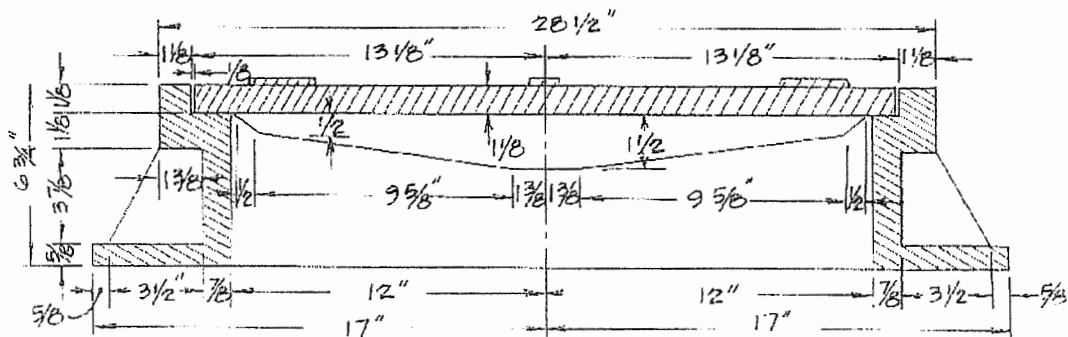
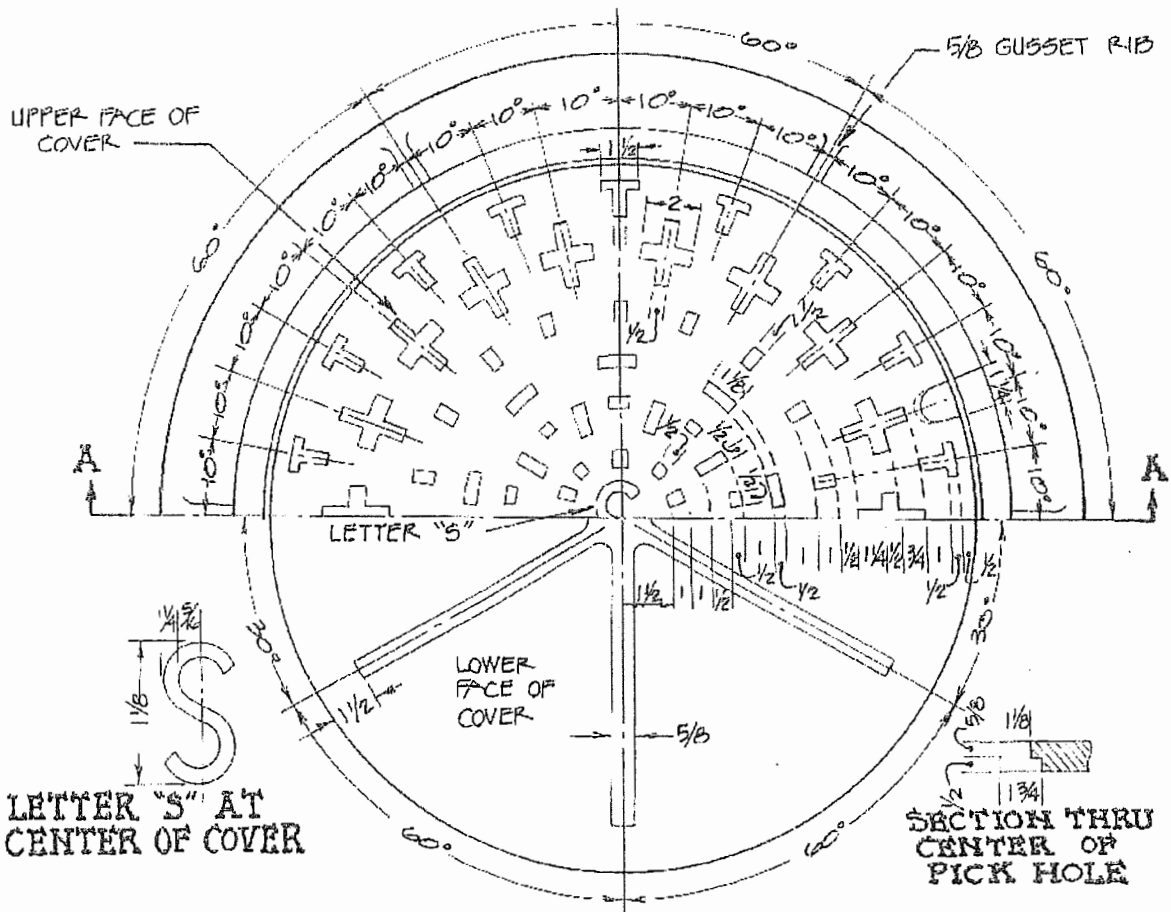

CALIFORNIA  
 CONCRETE  
 PIPE ASSY. A-201  
 FRAME - A-202  
 COVER - A-203  
 APPROX. WT. - 385#

MURPHYS SANITARY DISTRICT  
 STANDARD MANHOLE  
 COVER  
 N.T.S.

			SS-5
	4/29/09	G.G	
REV.	DATE	BY	



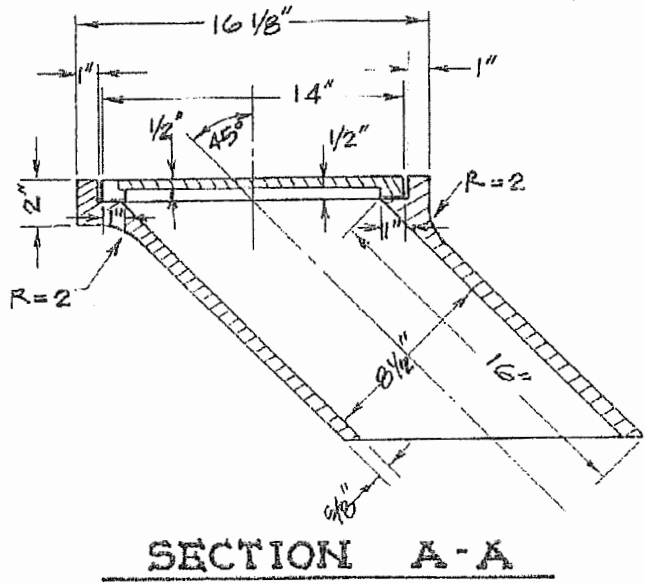
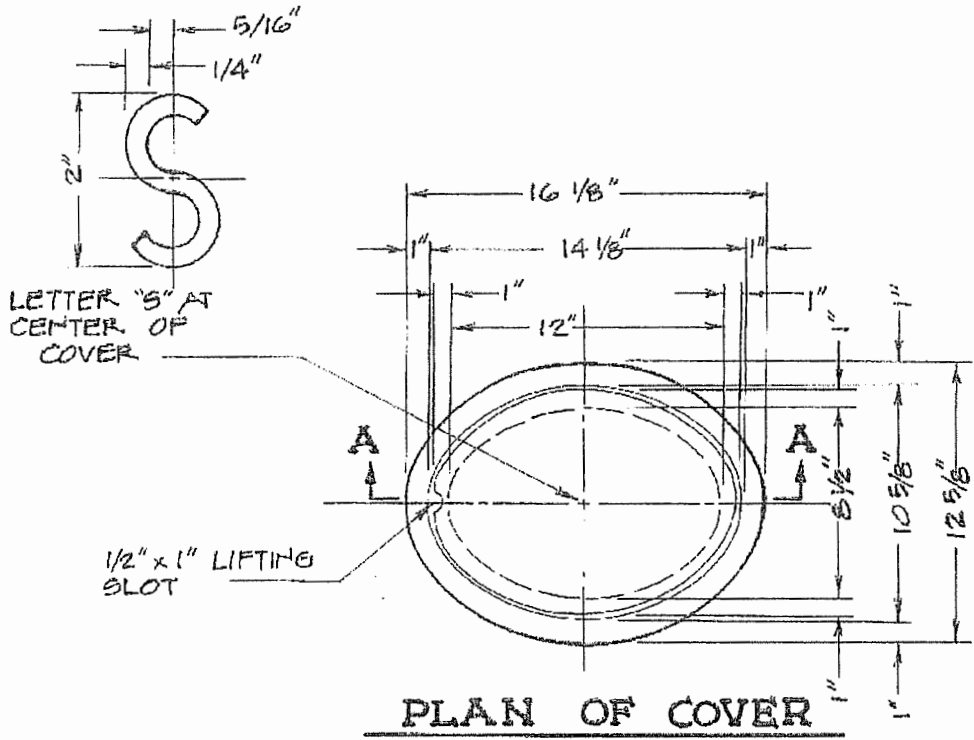

CALIFORNIA CONCRETE PIPE  
A-490 ASSY.

MURPHYS SANITARY DISTRICT

STANDARD  
CLEANOUT

N.T.S.

	4/29/09	G.G
REV.	DATE	BY

SS-7



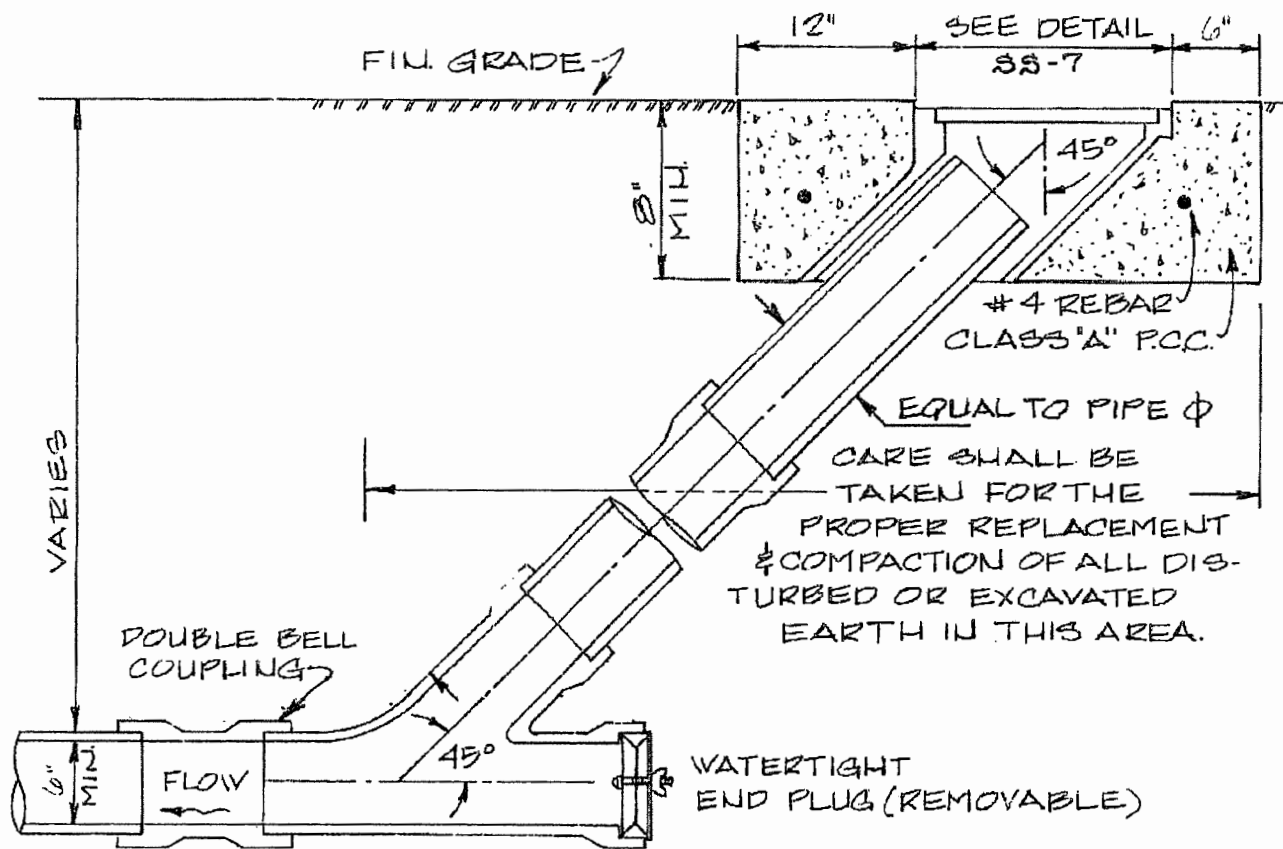

MURPHYS SANITARY DISTRICT  
 STANDARD FLUSHER  
 BRANCH & CLEANOUT  
 N.T.S.

	4/29/09	G.G
REV.	DATE	BY

SS-8

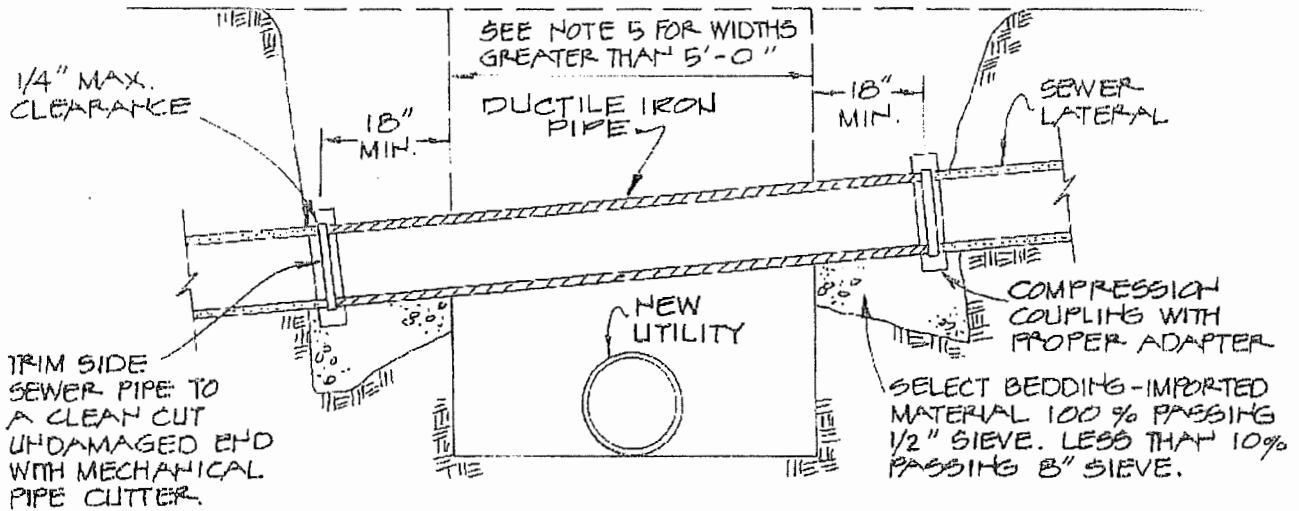

**NOTES**

1. INSIDE DIAMETER OF DUCTILE IRON PIPE TO BE THE SAME AS THE PIPE TO WHICH IT CONNECTS.
2. DUCTILE IRON PIPE IS TO BE USED AS PER THIS DETAIL WHENEVER THE SEWER LATERAL IS CUT OR DAMAGED.
3. DUCTILE IRON PIPE IS TO BE USED AS PER THIS DETAIL WHENEVER CONSTRUCTION PASSES BEHEATH THE SEWER LATERAL.
4. ALTERATION OF SEWER GRADES WILL BE PERMITTED ONLY AFTER WRITTEN PERMISSION HAS BEEN RECEIVED FROM ENGINEER.
5. WHENEVER THE SPAN, WHETHER CAUSED BY TRENCH WIDTH OR CROSSING ANGLE OF DUCTILE IRON PIPE EXCEED 5'-0", PLACE SELECT BEDDING TO 6" ABOVE THE CAST IRON PIPE AND 18" EACH SIDE OF ITS CENTER LINE.
6. PIPE CLASSES  
 4" CLASS 51 D.I.P.  
 6" AND LARGER CLASS 50 D.I.P.

MURPHYS SANITARY DISTRICT  
 STANDARD UTILITY  
 CROSSING  
 N.T.S.

			SS-9
	4/29/09	G.G	
REV.	DATE	BY	

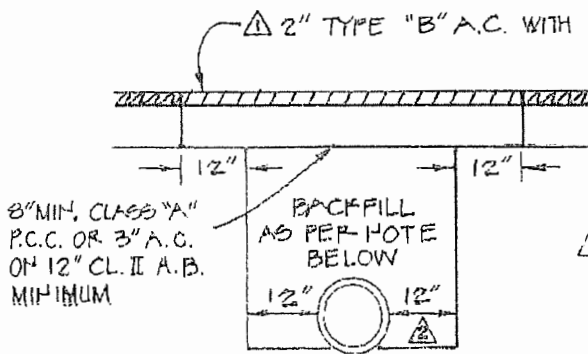

8" MIN. CLASS "A"  
P.C.C. OR 3" A.C.  
ON 12" CL. II A.B.  
MINIMUM

**TYPE "A"**

ASPHALT CONCRETE STREETS

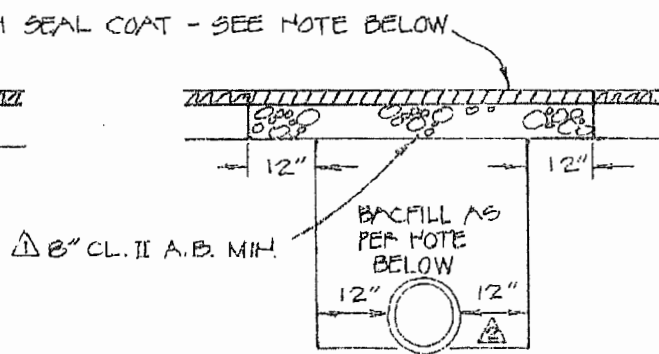

8" CL. II A.B. MIN.

**TYPE "B"**

ARMOR COAT OR  
SEAL COAT STREETS

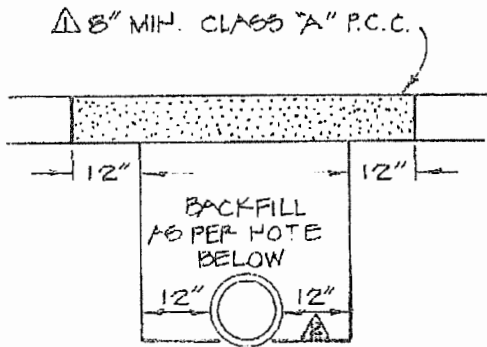

8" MIN. CLASS "A" P.C.C.

**TYPE "C"**

PORTLAND CEMENT CONCRETE  
STREET

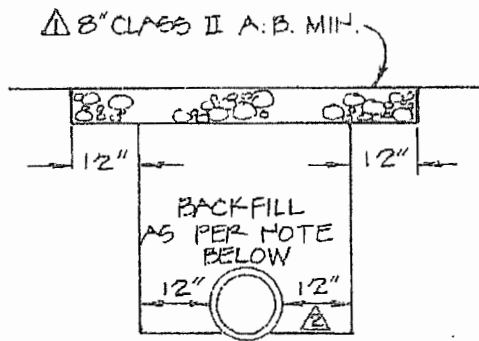

8" CLASS II A.B. MIN.

**TYPE "D"**

UNIMPROVED STREETS,  
ALLEYS OR EASEMENTS

**NOTES:**

ALL WORK SHOWN ABOVE SHALL CONFORM TO THE APPLICABLE SECTION OF THE STANDARD SPECIFICATIONS.

ALL EXCAVATION WITHIN PUBLIC RIGHT OF WAY SHALL BE BACKFILLED IN ACCORDANCE WITH SECTION 19-3 OF THE STANDARD SPECIFICATIONS.

AREA ADJACENT TO THE TRENCH SHALL BE LEFT IN A CONDITION EQUAL TO OR BETTER THAN THAT OF EXISTING PRIOR TO CONSTRUCTION.

SEAL COAT - BITUMINOUS BINDER SHALL BE COVERED WITH EITHER SAND OR SCREENINGS TO MATCH EXISTING SURFACE.

▲ STRUCTURAL SECTION ELEMENTS MAY BE INCREASED WHERE REQUIRED BY THE CITY ENGINEER DUE TO SOIL CONDITIONS AND TRAFFIC CONSIDERATIONS. THE REPLACEMENT STRUCTURAL SHALL EQUAL THE EXISTING STRUCTURAL SECTION AS A MINIMUM REQUIREMENT, EXCEPT THAT THE SECTION SHOWN ABOVE IS AN ABSOLUTE MINIMUM.

▲ MAXIMUM TRENCH WIDTH TO BE 24 INCHES PLUS OUTSIDE DIAMETER OF PIPE TO A HEIGHT OF 24 INCHES ABOVE THE TOP OF PIPE, NO EXCEPTIONS.

MURPHYS SANITARY DISTRICT  
STANDARD PAVEMENT  
REPLACEMENT & BACKFILL  
N.T.S.

	4/29/09	G.G
REV.	DATE	BY

SS-10

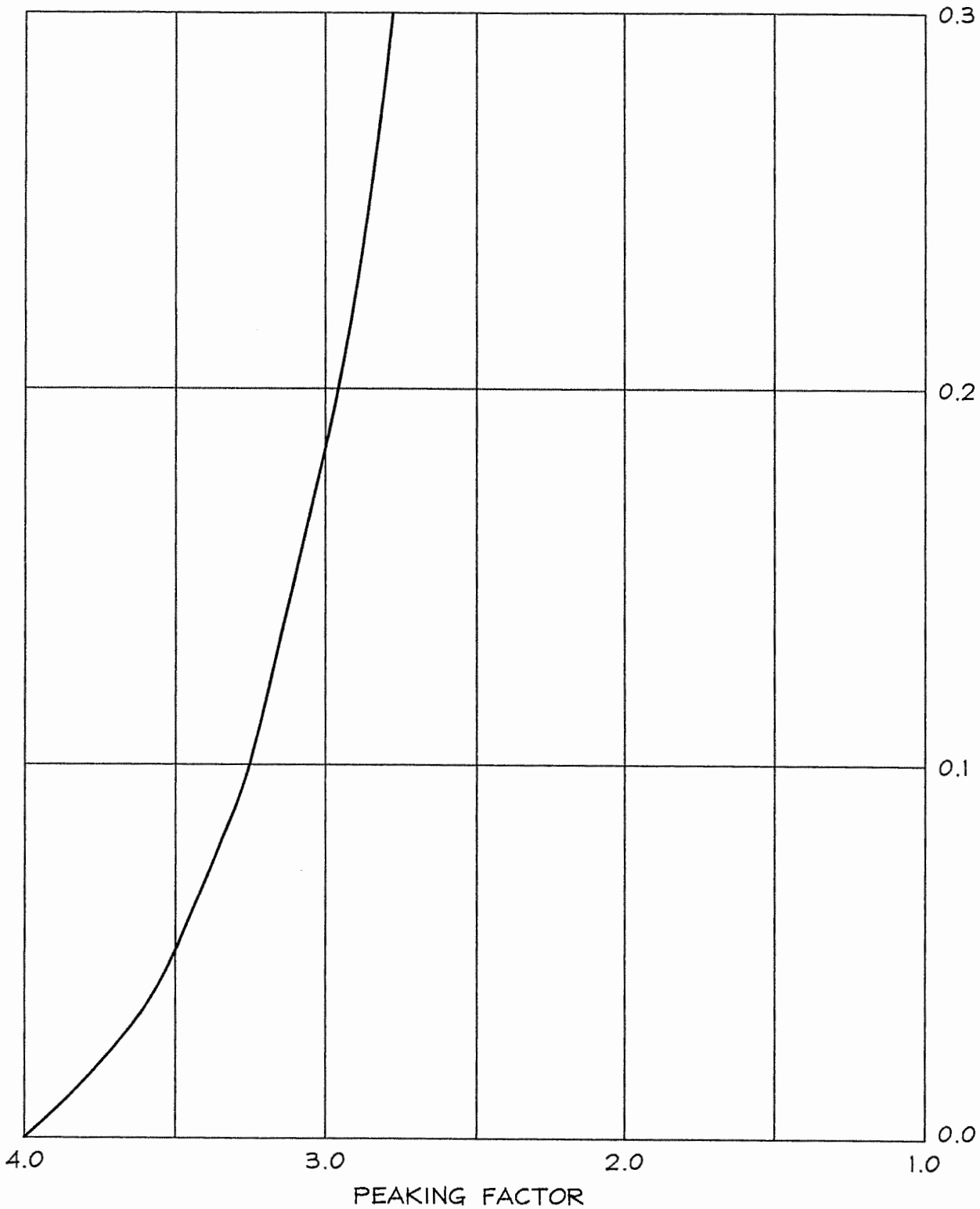

AVERAGE DAILY PROJECT FLOWS (M.G.D.)  
 RESIDENTIAL SEWAGE PEAK FLOW FACTORS  
 VS. AVERAGE DAILY FLOW

MURPHYS SANITARY DISTRICT

PEAK FLOW  
FACTORS

N.T.S.

	4/29/09	G.G
REV.	DATE	BY

SS-11